

User Manual

VT07-B21A/ VT07-B22A/ VT07-B23A/ VT10-B21A

Version: 1.0

Due to the regular upgrades of systems and products, ZKTeco could not guarantee exact consistency between the actual product and the written information in this manual.

Remark

Please follow the user manual for correct installation and testing. If there is any doubt please call our tech-supporting and customer center.

Our company applies ourselves to reformation and innovation of our products. No extra notice for any change. The illustration shown here is only for reference. If there is any difference, please take the actual product as the standard.

The product and batteries must be handled separately from household waste. When the product reaches the end of service life and needs to be discarded, please contact the local administrative department and put it in the designated collection points in order to avoid the damage to the environment and human health caused by any disposal. We encourage recycling and reusing the material resources.

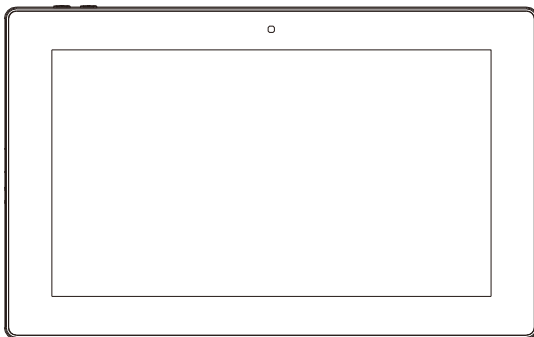

CATALOG

Product Features	1
Technical Parameters	1
Product Executive Standard	2
Pictures	3
Operations	5
1. VOIP	6
2. Security.....	12
3. Elevator	20
4. Service.....	20
Web Settings	23
System Configuration	27
System Diagram	28
Installation.....	30
Troubleshooting.....	33
Safety Precaution	34

Product Features

1. Building intercom application:

VOIP: Support video call, monitoring, unlocking, VOIP communication and call record checking.

Security: Support 8 alarm zones with 3 states, alarm zone and scene setup.

Others: Support Android systems applications.

Support connection to audio extension (VT07-B21A/VT07-B22A/VT07-B23A/VT10-B21A optional).

Support Wi-Fi network communication and Bluetooth transmission (Optional).

2. Operating system: VT07-B21A system: Android 4.4.2

VT07-B22A/VT07-B23A/VT10-B21A: Android 6.0.1

Technical Parameters

Voltage: DC 12V

POE (VT07-B21A/VT07-B22A/VT07-B23A/VT10-B21A optional)

Rated power: 10W

Standby power consumption: 3W

Display screen: 7" / 10.1"

Touch screen: capacitive touch screen

Resolution: 10.1": 1024X600(VT10-B21A)

7": 1024X600(VT07-B21A/VT07-B22A/ VT07-B23A)

Camera: 640x480CMOS (Optional)

Operating temperature: -10°C~+55°C

Storage temperature: -10°C~+60°C

Storage Relative humidity: 20%~85%

Memory: 512MB

1GB (optional)

CPU: Quad core 1.3GHz

Flash: 4GB

Product Executive Standard

- ◇ GB/T 31070.1-2014 "Building Intercom Systems—Part 1: General Technical Requirements".
- ◇ GA 1210-2014 "Security Technical Requirements for Building Intercom Systems".
- ◇ GB/T12663-2019 "General Specifications for Burglar-alarm Control Units".
- ◇ GB/T 32581-2016 "Specifications for Intrusion and Hold-up Alarm System".
- ◇ GB/T 31070.2-2018 "Building Intercom System Part 2: Technical Requirements for Digital Building Intercom Systems".
- ◇ GB/T 31070.4-2018 "Building Intercom System Part 4: Application Guidelines".
- ◇ GB/T 37845-2019 "Technical Requirements for Home Security Intelligent Management Systems".
- ◇ DB31 / T294-2018 "Requirements of Intelligent Security Technology in Residential District".
- ◇ DB31T 1086-2018 "Requirements of Applications for Intrusion Alarm System".

Pictures

Model: VT10-B21A

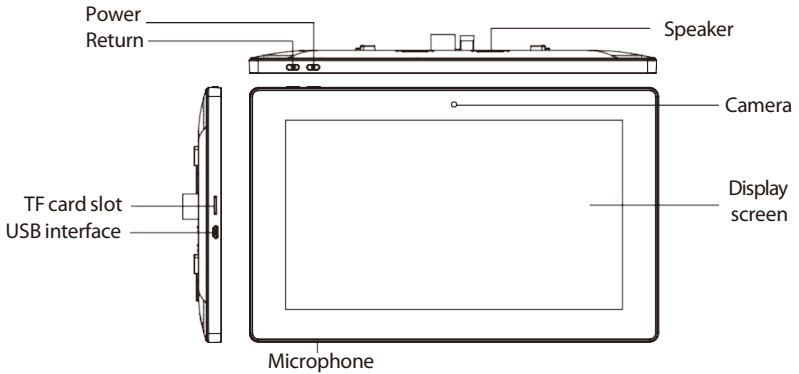

Model: VT07-B23A

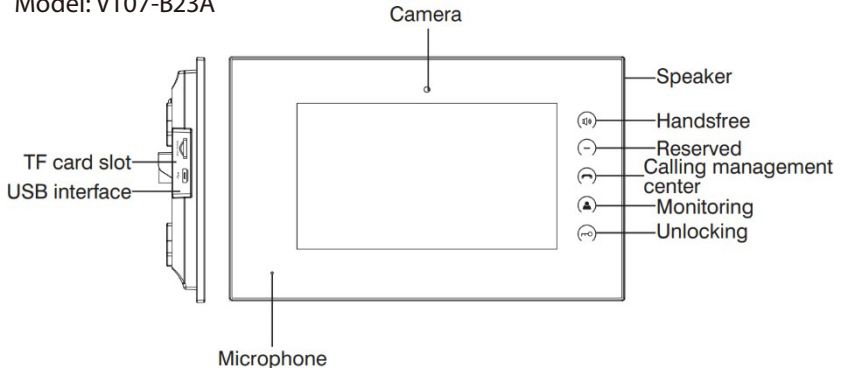

Model: VT07-B21A/VT07-B22A

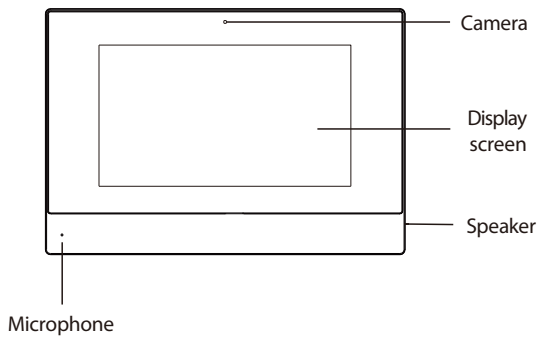

Operations



Main interface: VOIP, Security, Service, Contacts, Calendar, Media player.

Shortcut key: Elevator, Out, Unlock and Apps.





1. The main interface will remind user when there are missed calls, unread MSG and SMS.

2. The state of weather is synchronously updated by NTP.

Status bar: Return, Main interface, Background program, Volume-, Volume+.

When the user enters into secondary menu, the interface displays the following icons at the bottom of the screen.

Status bar instruction:

1. Return : Click it to return to previous menu.
2. Main interface : Click it to return to main interface.
3. Background program : Click it to display the operating program running in the background.
4. Volume- : Click it to reduce the volume.
5. Volume+ : Click it to increase the volume.

1. VOIP

Clicking "VOIP" icon on the main interface, the system will enter the following interface:

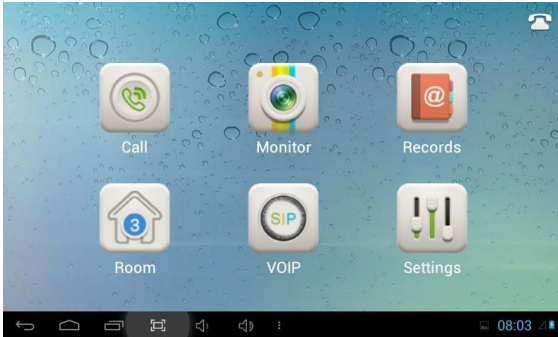

1.1 Call

Clicking "Call" icon, the system will enter the following interface:

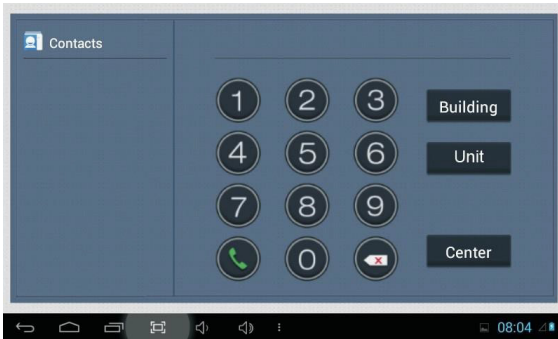

1.1.1 Call unit resident

Input 1-3 digits building No.+ "Building" + 2-digit Unit No. + "Unit" +4-digit room No., then click  icon to call.

The system will enter into the following interface:

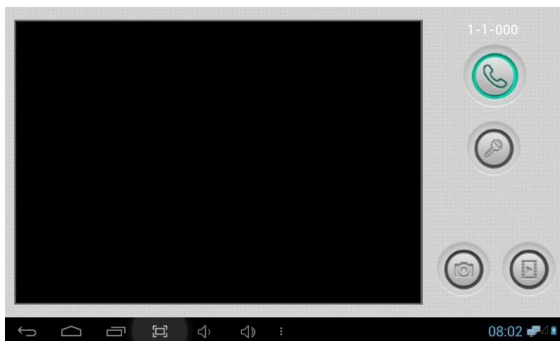

When the call is answered, the system will enter into call state:



① If there is a camera, the caller's image will be displayed on the screen;

② When the call is answered, the video will be uploaded into the indoor monitor.

When the outdoor panel, wall panel or flat camera calls, the indoor monitor will ring; when outdoor panel calls indoor monitor, the image from outdoor panel will be displayed on the indoor monitor; if there is no answer within 25 seconds, the call will be ended.

Click  icon to communicate with outdoor panel; click  icon to end the call; click  icon to unlock the door.

Remark: visual intercom function between households is optional.

You can make audio and video recording during communication (TF card should be inserted into indoor monitor).  icon to take a snapshot of the visitor; click  icon to save the video and image for current communication.

The system's default call duration is 120s.

1.1.2 Call management center





Clicking "Center" icon to call management center, the system will call management center No.1-No.5 successively. If the management center cannot be searched or call failed, the system will automatically call next management center. When the management center answers, it will ring and stop calling next one.

Click  icon to end the communication.

1.2 Monitor







Clicking "Monitor" icon, the system will enter the following interface:











Click "Door01" icon to switch outdoor panel and flat camera mode, then click  or  icon to select the area you want to monitor, and click  icon to monitor the outdoor panel or flat camera.  icon to end monitoring. Click  icon to unlock the door. Remark: The system's default monitoring time is 25s.

1.3 Records

Clicking "Records" icon, the system will enter the following interface:

NO.	Number	Date	Length
 1	toto	70-01-02 08:13:17	45s
 2	toto	70-01-02 08:10:24	22s
 3	1019003	70-01-02 08:09:30	17s
 4	1019003	70-01-02 08:08:44	42s
 5	1019003	70-01-02 08:07:56	21s
 6	1019003	70-01-02 08:07:11	42s

 refers to call-out record;  refers to call-in record;  refers to missed call record. It can save up to 64 records.

Click  or  icon to search for records. Select one record and click  icon to call; click  icon to delete it. Click  icon to back-up.

If there is snapshot image, click  icon to view it.

1.4 Room

Click "Room" icon, then input 1-16 digits password (the default password is 123456) to enter into the following interface:

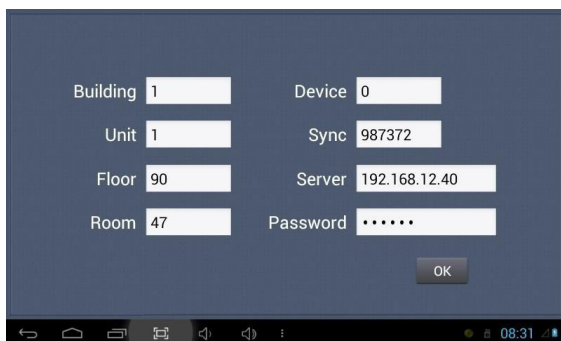

Warning: Please revise synchronous No.(6 digits) as soon as possible after you read the user's manual. The synchronous No. of all indoor monitors in one household must be the same.

Input the 3-digit Building No. such as 001, and then click "OK" to finish the building No. setting.

The setting method of Unit No., Floor No., Room No., Device No. and Synchronous No. is the same as the one of Building No.. The Unit No., Floor No. and Room No. are limited to 2 digits respectively. When Device No. is set to be 0, the indoor monitor is regarded as the main; when Device No. is set from 1 to 5, as the sub1 to sub5.

1.5 VOIP

Clicking "VOIP" icon, the system will enter the following interface:



Proxy: sip proxy server URL, the form is sip:ip or sip: realm name.

Realm: the scope for the device, is the same with IP or realm name.

Password: the password to access proxy server, offered by the administrator of sip proxy server.

Stun IP and port: the public network server IP and port crossed by audio/video NAT.

To connect with SIP phone, check "Enable" and input the registered SIP account.

1.6 Settings

Clicking "Settings" icon, the system will enter the following interface:

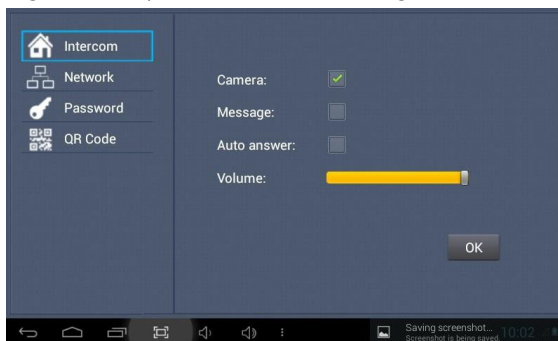

1.6.1 Intercom

Check "Camera", "Message" or "Auto answer" to enable corresponding function, then click "OK" icon.

1.6.2 Network

Click "Network" icon to enter into the following interface:

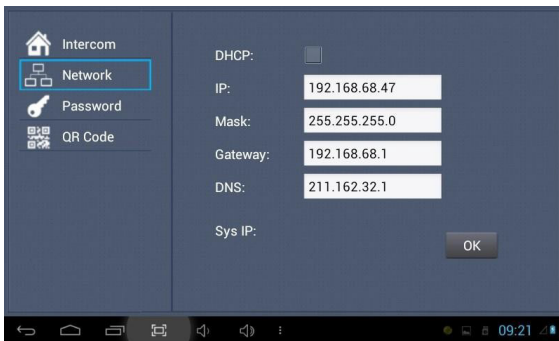

After using the DHCP, the router will automatically distribute IP address.

Other settings are the same as the ones of Apps.

Sys IP: the system will automatically display IP address of the indoor monitor. IP address is unique.

The default Mask address is 255.255.255.0. Normally, it is unnecessary to modify. If you would like to modify it, clicking the setting box twice, a keypad will pop up. Enter your new Mask address.

The Gateway in one system must be in the same segment.

DNS: domain name resolution address (DNS of local operator). If the indoor monitor is used in external network, the address must be completed correctly; if it is used in internal network, the address can be ignored.)

Click "OK" to save the settings.

Remark: the settings should be made after inputting password to enter into room No. settings.

1.6.3 Password

Clicking "Password" icon to enter into the following interface:

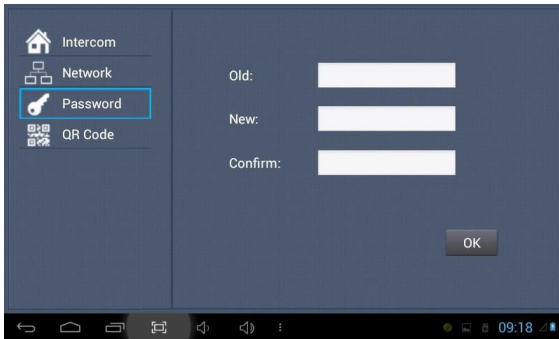

You can set the new system password with 1-16 digits (the default password is 123456). System password is used for system settings.

1.6.4 QR Code

Click "QR Code" icon to enter into the following interface:



Scanning the QR code with mobile APP, it will be synchronized with the indoor monitor.

2. Security

Clicking "Security" icon on the main interface, the system will enter into the following interface:

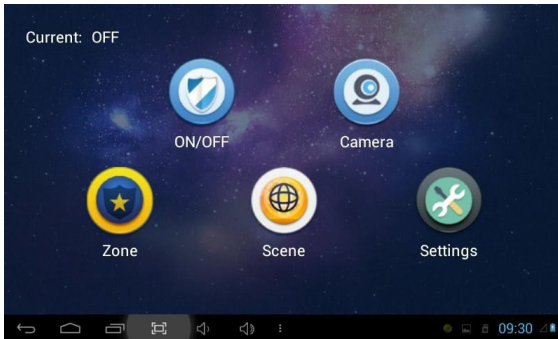

2.1 ON/OFF

Clicking "ON/OFF" icon, the system will enter the following interface:

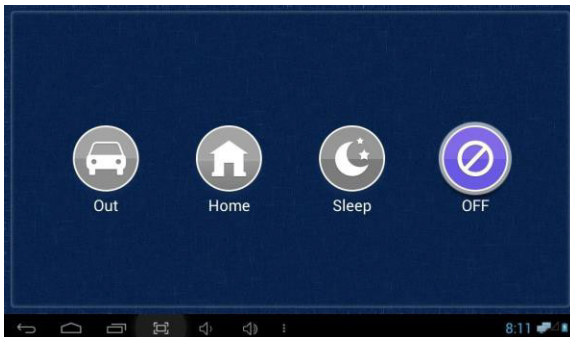

2.1.1 ON

Clicking "Out", "Home", or "Sleep" icon to activate the alarm sensors, the icon on the main interface will light with a "Di-Di" tone and this icon will always light up.

2.1.2 OFF

- (1) During the alarm delay time, clicking "OFF" icon, the system will give a tone, then the alarm is disabled.
- (2) Input user password (the default password is 1234) to disable the alarm under alarm ON status.

2.2 Camera

Clicking "Camera" icon, the system will enter into the following interface:

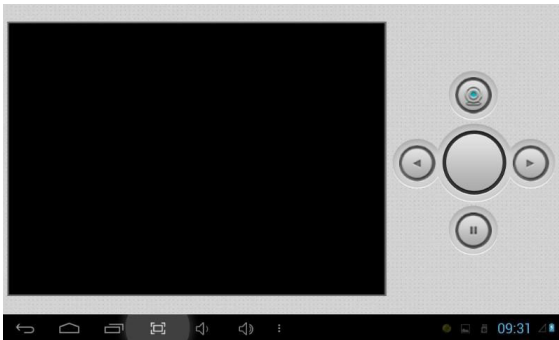

Click "⏪" or "⏩" button to select camera you want, and then click "📷" to monitor the IP camera. During the monitoring, if you want to cancel monitoring, click "⏹" to stop it.

2.2.1 IP Camera Setting

Login the webpage of indoor monitor by username: user, password:1234, then you can access the following webpage:



Fill the RTSP format: rtsp:// user: password@ Camera IP. IP is the IP address of your IP Camera. Then you can monitor IP Camera in Security menu on your indoor monitor:

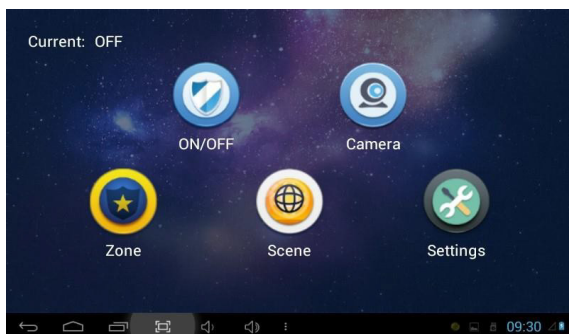

Clicking "Camera" icon, the system will enter into the following interface:



Click "←" or "→" button to select IP Camera to monitor, and then click "⏸" icon to monitor. Click "⏹" to stop monitoring.

2.3 Zone

Remark: the settings should be made when alarm is OFF.

Clicking "Zone" icon and inputting 1-16 digits password (the default password is 1234), the system will enter into the following interface:

NO.	Type	Mode	Delay	Sensor
1	Normal	3C	0s	Smoke
2	24 Hour	3C	0s	Smoke
3	24 Hour	3C	0s	Smoke
4	Normal	3C	0s	Smoke
5	24 Hour	3C	0s	Smoke
6	Emerg.	3C	0s	Smoke
7	24 Hour	3C	0s	Smoke
8	24 Hour	3C	0s	Smoke

2.3.1 Alarm Type

Clicking type input box, it will pop up a dialog box as the following. In this interface, you can set alarm Type as: Normal, Emergency and 24H. 24H and Emergency type are always active.

NO.	Type	Mode	Delay	Sensor
1	Normal	3C	0s	Smoke
2	24 Hour	3C	0s	Smoke
3	Normal	3C	0s	Smoke
4	Emerg.	3C	0s	Smoke
5	24 Hour	3C	0s	Smoke
6	Emerg.	3C	0s	Smoke
7	24 Hour	3C	0s	Smoke
8	24 Hour	3C	0s	Smoke

2.3.2 Mode

Clicking mode setting box, it will pop up a dialog box as the following interface.

In this interface, you can set mode as: 3C, NO, NC and BELL.

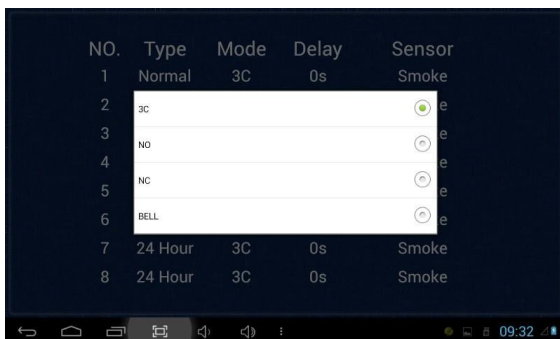

2.3.3 Delay Time

It refers to the delay time of giving an alarm. Clicking Delay setting box, it will pop up a dialog box as the following interface with selections: 0s, 5s, 15s, 20s, 25s, 40s or 60s as the desired delay time. For example, you select the delay time: 5s. Once the alarm sensor is triggered, 5 seconds later, the indoor monitor will sound sirens.

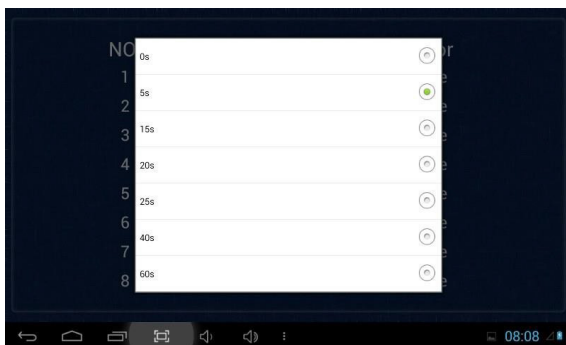

2.3.4 Sensor Type

Clicking sensor type input box, it will pop up a dialog box as the following interface. Each sensor type can be set up as: Smoke, Gas, PIR, Door, Window, Panic, Flood, Pull Cord or Bed Mat.

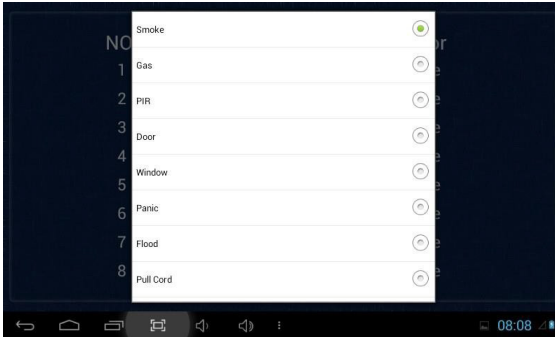

When alarm sensor is triggered, the indoor monitor will make a loud alarm sound. The system will enter into the following interface and send alarm message to management center (if your system is installed with management center):

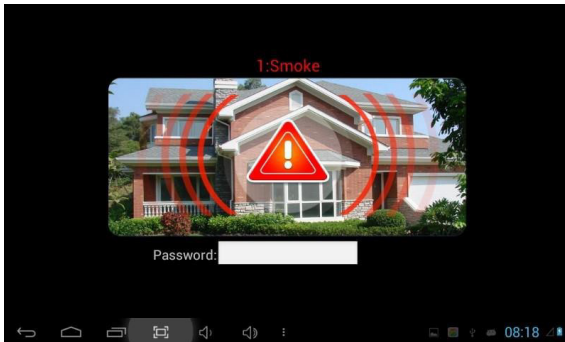

You can see the No. and sensor type in red showed at the top of interface. For example: "2:Smoke" indicates that in Zone 2 Smoke sensor is triggered.

To stop the alarm sound, input the password (the default password is 1234).

2.4 Scene

Clicking "Scene" icon, the system will enter into the following interface:

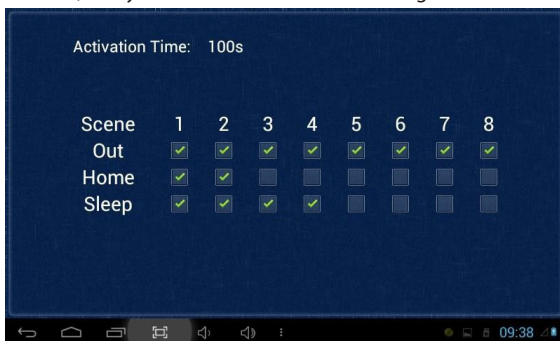

refers to Alarm ON, refers to Alarm OFF. To set the sensor of alarm stations, you can click the corresponding station with icon. Click activation time to choose the corresponding time. The options of activation time include NONE, 30s, 40s, 60s, 100s and 300s.

2.5 Settings

Clicking "Settings" icon, the system will enter into the following interface:

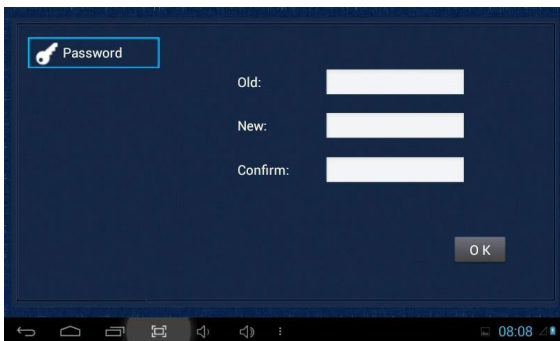

You can set the new user password with 1-16 digits (the default password is 1234). User password is used for security.

3. Elevator

Clicking “Elevator” icon, the system will enter into the following interface:

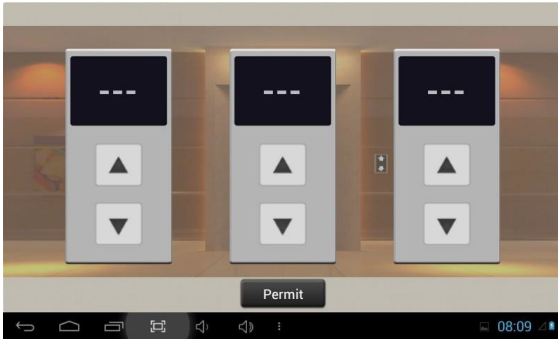

Click ▲ or ▼ icon to control the elevator to go up and down. Click “Permit” icon to allow access to the floor where the indoor monitor is located.

Remark: To support this interface, your system must connect with “Elevator Control” module. Kindly check with your system provider.

4. Service

Clicking “Service” icon on the main interface, the system will enter into the following interface:

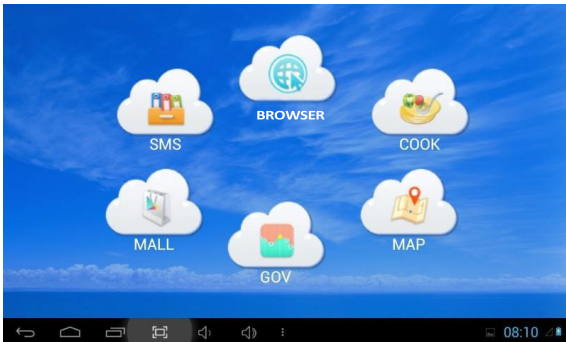

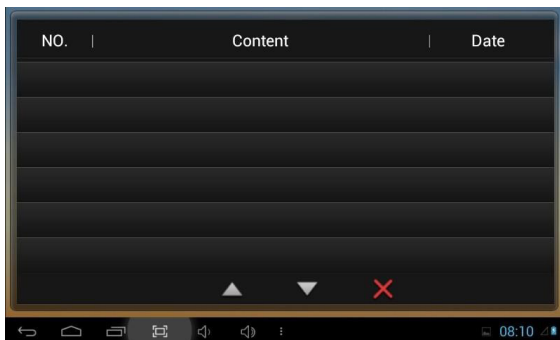

4.1 SMS

Clicking "SMS" icon, the system will enter into the following interface:



Note: only clicking the management software on PC which is usually located at guard center, so can indoor monitor receive the message sent by PC.

Click  icon to page up; click  icon to page down; click  icon to delete the record. 64 records can be received in SMS at most.

4.2 BROWSER

Clicking "BROWSER" icon, the system will enter into the web page linked with the indoor monitor (the function should be supported by external network).

You can also set the default link for "COOK", "MAP", "GOV" and "MALL" in the webpage on indoor monitor.

Web Settings

Please refer to 1.6.2 to view IP address.

Connect the indoor monitor and computer by network switch. Input the indoor monitor's IP address in the browser, then input user name and password (the default user name is "admin", the password is "123456") to enter into the web setting interface.



1. Network

Click "Network" icon to enter into the following interface:



The user can change the IP address of indoor monitor here. Checking the box of the ethwifi, wifi and wired network will work synchronously, but this is only valid for those indoor monitors with wifi function.

2. RoomNo

Click "RoomNo" icon to enter into the following interface:



The settings are the same as the ones of indoor monitor.

3. VOIP

Click “VOIP” icon to enter into the following interface:



The screenshot shows the 'SIP Settings' page of the Streaming Media Solution. The page has a green header with the title 'Streaming Media Solution' and a navigation menu on the left with options: Main, Network, Account, VOIP, Advanced, WebStat, License, and Logout. The main content area is titled 'SIP Settings' and contains the following fields:

- SIP enable:
- Proxy:
- Realm:
- Outbound:
- STUN IP:
- STUN Port:
- User:
- Password:
- Timeout:
- HostOut:

At the bottom of the form is a 'Submit' button.

The settings are the same as the ones of indoor monitor.

To connect with SIP phone, check “SIP Enable”, and input the number registered in SIP server.

Timeout: Talking time settings.

Click “Submit” icon to save the settings.

4. Advanced

Click “Advanced” icon to enter into the following interface:



The screenshot shows the 'Advanced Settings' page of the Streaming Media Solution. The page has a green header with the title 'Streaming Media Solution' and a navigation menu on the left with options: Main, Network, Account, VOIP, Advanced, WebStat, License, and Logout. The main content area is titled 'Advanced Settings' and contains the following fields:

- Ex Phone:
- URL:
- Ex Phone:
- URL:
- Auto Pickup:
- Quick Call:
- URL:
- DTMF Unlock:
- DTMF:

At the bottom of the form is a 'Submit' button.

Ex Phone: input IP address of other manufacturer’s SIP device. It refers to other factory’s VOIP device which is used as sub indoor monitor. When outdoor panel calls indoor monitor, SIP device will ring at the same time. Other terminals will stop ringing when one of the indoor monitor or SIP device answers the call.

Auto Pickup: checking the box, the indoor monitor will automatically answer the call, when outdoor panel calls but there is no answer within 10s.

Quick Call: If you want to click Center icon to call other SIP device (for example IP address is 192.168.15.100), you can check this option, input for example sip:1@192.168.15.100 (1 can be any number), and then save the settings.

When you click the icon, it will call this SIP device.

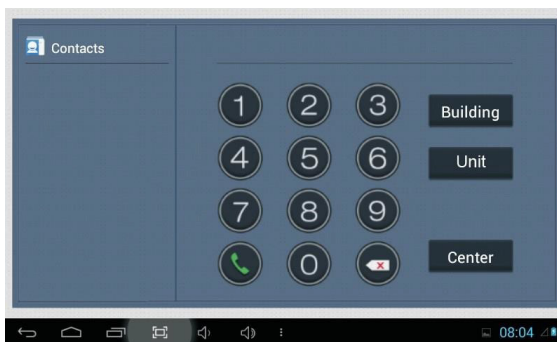

Remark: the address can be the SIP address of indoor monitor or other factory's VOIP device. Click "Submit" icon to save the settings.

5. Webkit

Click "Webkit" icon to enter into the following interface:



Advertising: use web page as the image. Checking the box, when there's advertisement pushed from management software, it will display when the indoor monitor is in standby state.

Browser: input the linking address in the box. As there is a “BROWSER” icon on the indoor monitor, when the user clicks the icon, it will switch into the linked web page.
Click “Submit” icon to save the settings.

6. License

It is reserved.

7. Logout

Click “Logout” icon to enter into the following interface:



Clicking “Submit” icon, the user will log out of the system.

System Configuration

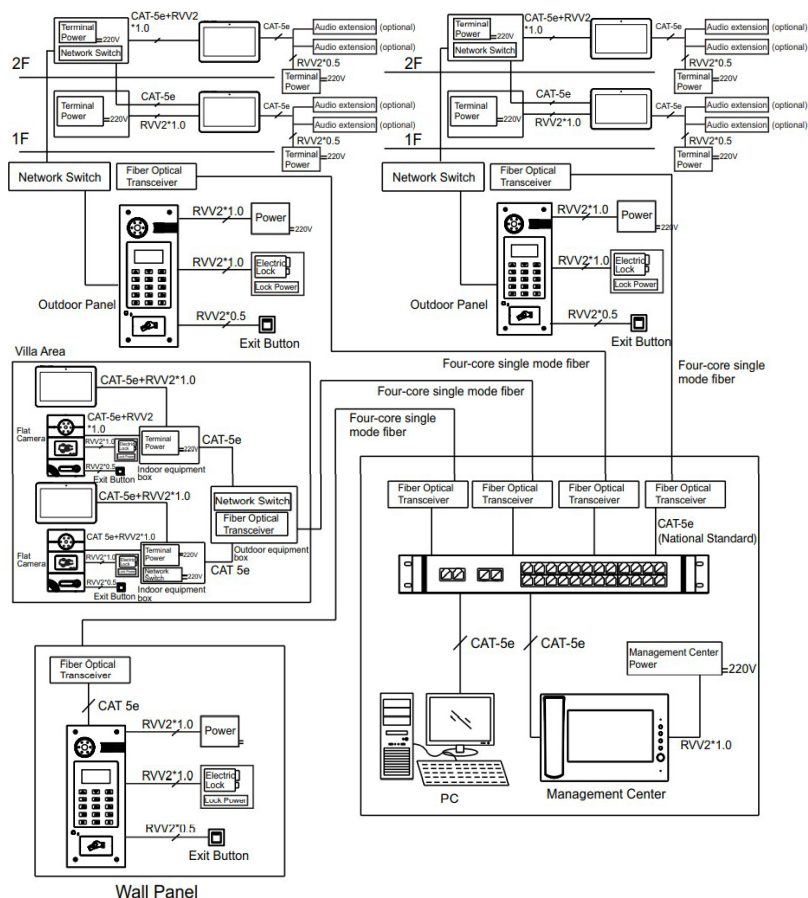

System Diagram

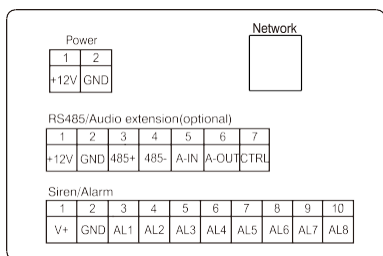

Standard

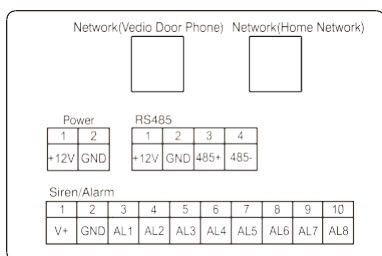

Dual Ports

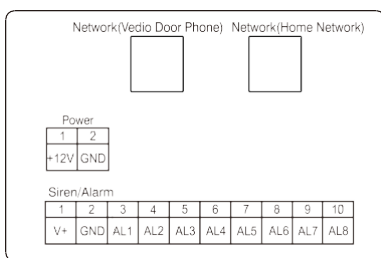

Dual Ports (Without RS485)

1. Power

Power input interface connect with 12V power adapter.

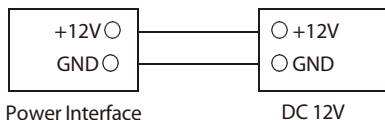

2 Network

Connect with outdoor panel, indoor monitor or other network equipment by network switch.

When indoor monitor has POE function, the interface can supply power by connecting with POE network switch. If network interface has 12V power supply, pin No. 4 and 5 of RJ45 interface should connect with +12V of power interface, and pin No. 7 and 8 should connect with GND of power interface.

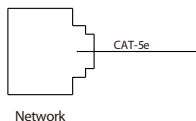

3. RS485/Audio extension

When there is audio extension, the audio extension interface and RS485 interface can be connected to the audio extension.

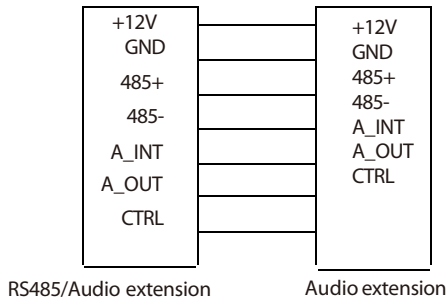

4. RS485

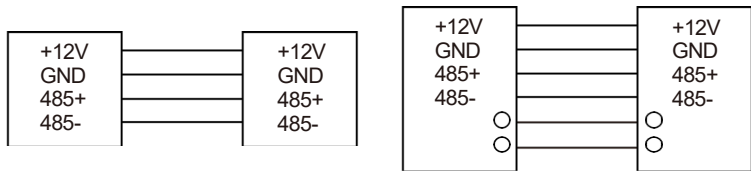

5. Alarm interface

Interface of alarm zones connects with normally-open or normally-closed switch. When the alarm zone is triggered, it will output 12V/100mA power.

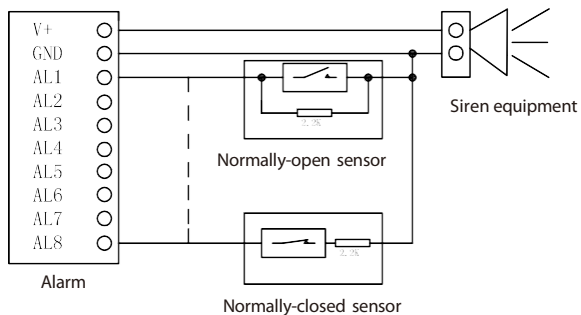

Installation

Model: VT10-B21A

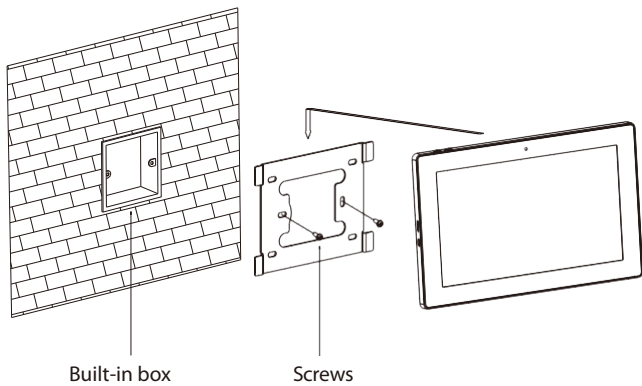

Size: 270*168*15mm

Model: VT07-B23A

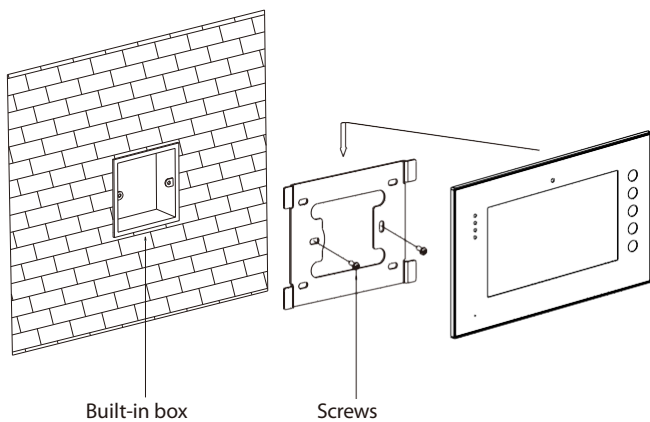

Size: 235*145*19,5mm

Model: VT07-B21A/VT07-B22A

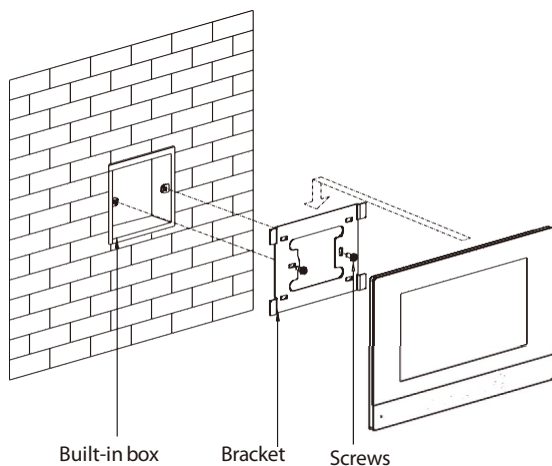

Size: 221.4*151.4*16.5mm

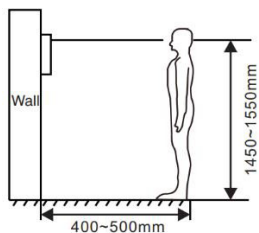

[Suggestion]: During the installation, the camera should be 1450~1550mm above the ground. The camera angle for photographing human face should be the top priority.

Troubleshooting

The indoor monitor cannot start up or power off automatically.

- Check whether it has power-failure, and power it on again.

The indoor monitor display screen is too dim.

- Check whether the brightness and contrast settings of screen are correct.

No sound during the communication.

- Check whether the indoor monitor is set as mute mode, or the volume is set to the lowest.

The indoor monitor cannot monitor the outdoor panel.

- Other user is using the system, so you can use it once he/she finished the operation.

Multimedia files cannot be played normally.

- Check whether the system supports the file format. Please refer to multimedia setting for details.

No response when clicking indoor monitor display screen.

- Press “Unlock” button for 5s, or slowly slide horizontally or vertically on the LCD to make touchscreen calibration. It needs to be calibrated twice.

Touchscreen responses slowly or cannot make calibration.

- Take down any protective paster, since it may affect identification and input for device;
- Ensure the finger is dry and clean when clicking touchscreen;
- Restart the device to clear any temporary software error.

The temperature of device is too high.

- Long-term use leads to high temperature. It's normal and will not affect the device's use life and performance.

Safety Precaution

In order to protect you and others from harm or your device from damage, please read the following information before using the device.

Do not install the device in the following places:

- Do not install the device in high-temperature and moist environment or the area close to magnetic field, such as the electric generator, transformer or magnet.
- Do not place the device near the heating products such as electric heater or the fluid container.
- Do not place the device in the sunshine or near the heat source. This might cause discoloration or deformation of the device.
- Do not install the device in an unstable position to avoid the property losses or personal injury caused by the falling of device.

Guard against electric shock, fire and explosion

- Do not use damaged power cord, plug or loose outlet.
- Do not touch the power cord with wet hands or unplug the power cord by pulling.
- Do not bend or damage the power cord.
- Do not touch the device with wet hands.
- Do not make the power supply slip or cause the impact.
- Do not use the power supply without the manufacturer's approval.
- Do not have the liquids such as water go into the device.

Clean Device Surface

- Clean the device surfaces with soft cloth dipped in some water, and then rub the surface with dry cloth.

Other Tips

- In order to prevent damage to the paint layer or the case, please do not expose the device to chemical products, such as the diluent, gasoline, alcohol, insect-resist agents, opacifying agent and insecticide.
- Do not knock on the device with hard objects.
- Do not press the screen surface. Overexertion might cause flopper or damage to the device.
- Please be careful when standing up from under the device.
- Do not disassemble, repair or modify the device at your own discretion. The arbitrary modification is not covered under warranty. When any repair required, please contact the customer service center.
- If there is abnormal sound, smell or fume in the device, please unplug the power cord immediately and contact the customer service center.
- When the device isn't used for a long time, the adaptor and memory card can be removed and placed in dry environment.
- When moving, please hand over the manual to new tenant for proper usage of the device.

Other notes

In order to prevent paintcoat or outer skin from damage, don't make the device contact with chemicals, such as diluent, gasoline, alcohol, insect-resist agents, opacifier, insecticide, etc.

- Don't knock or beat the device with hard materials.
- Don't put pressure on display screen. Pressing too hard may lead to frame stoppage or damage for the device.
- If you are sitting under the device, please pay more attention when standing up.
- Don't disassemble, configure or fix the device by yourself. The manufacturer will not guarantee for such change or configuration of device. To repair, please contact customer service center.
- If the device makes strange sound, taste or smoke, please unplug the power supply immediately and contact customer service center in time.
- If the device isn't used for a long time, we suggest to unplug the power adapter and SD card, and place it on the dry environment.
- Please hand over the instruction to new owner for proper usage of the device.

ZKTeco Industrial Park, No. 32, Industrial Road,
Tangxia Town, Dongguan, China.

Phone : +86 769 - 82109991

Fax : +86 755 - 89602394

www.zkteco.com

