

User Manual

VEX-B24A

Version: 1.0

Due to the regular upgrades of systems and products, ZKTeco could not guarantee exact consistency between the actual product and the written information in this manual.

REMARK

Please follow the user manual for correct installation and testing. If there is any doubt please call our tech-supporting and customer center.

Our company applies ourselves to reformation and innovation of our products. No extra notice for any change. The illustration shown here is only for reference. If there is any difference, please take the actual product as the standard.

The product and batteries must be handled separately from household waste. When the product reaches the end of service life and needs to be discarded, please contact the local administrative department and put it in the designated collection points in order to avoid the damage to the environment and human health caused by any disposal. We encourage recycling and reusing the material resources.



CATALOG

PRODUCT FEATURE	- 1 -
TECHNICAL PARAMETER.....	- 1 -
PACKAGE CONTENT.....	- 2 -
OVERVIEW	- 3 -
BASIC OPERATION.....	- 4 -
DEVICE SETTING.....	- 5 -
WEB SETTING.....	- 9 -
SYSTEM DIAGRAM.....	- 21 -
DEVICE WIRING.....	- 22 -
INSTALLATION	- 24 -
TROUBLESHOOTING.....	- 29 -
SAFETY INSTRUCTION.....	- 30 -

PRODUCT FEATURE

1. Induction loop for hearing impaired
2. Braille dot for visually impaired
3. 3 output relays for door locks
4. Tamper alarm
5. Facial Recognition (No distortion)
6. Support Face, IC (13.56MHz) & ID (125kHz) card, PIN code
7. 2MP camera with WDR mode

TECHNICAL PARAMETER

Power Supply: PoE+ (802.3at) or DC 12V/2A

Standby Power: 8 W

Rated Power: 16 W

Resolution: 480 x 272

Working Temperature: -40°C to +55°C

Storage Temperature: -40°C to +70°C

Working Humidity: 10% to 90% (non-condensing)

PACKAGE CONTENT

MODEL: VEX-B24A (Surface Mounting)

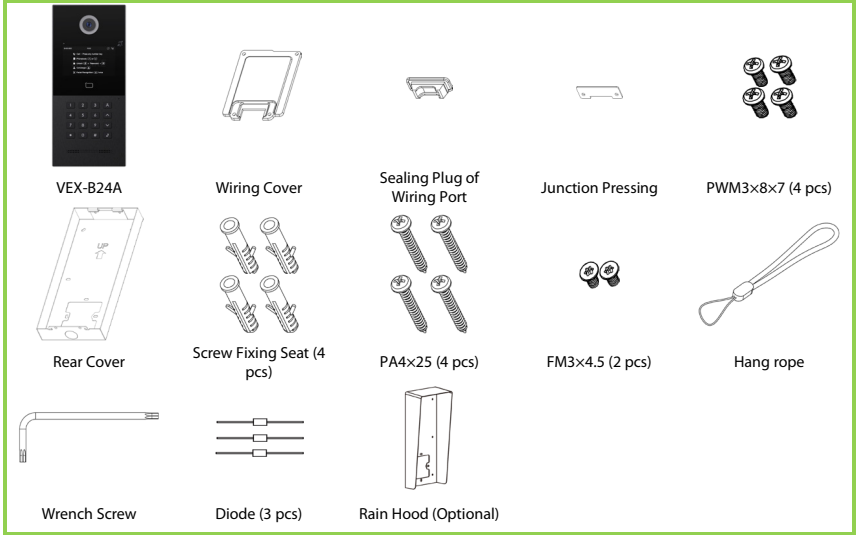

MODEL: VEX-B24A (Flush Mounting)

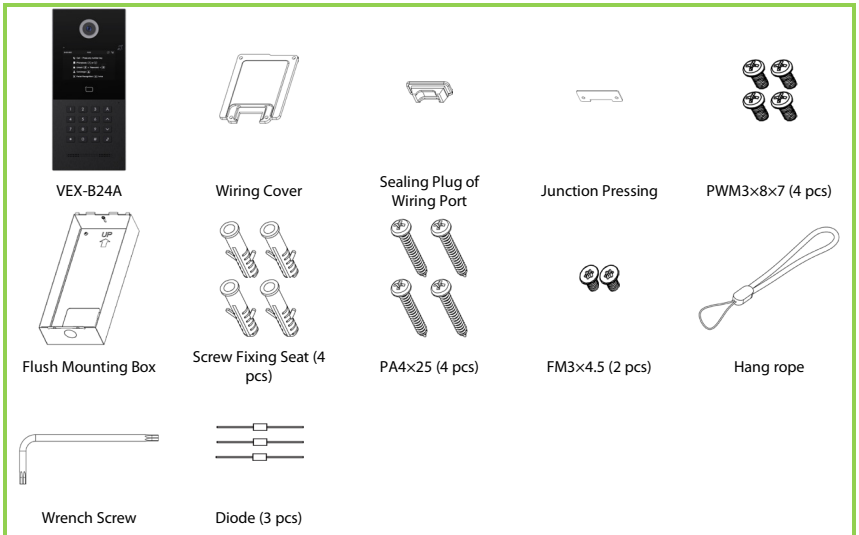

OVERVIEW

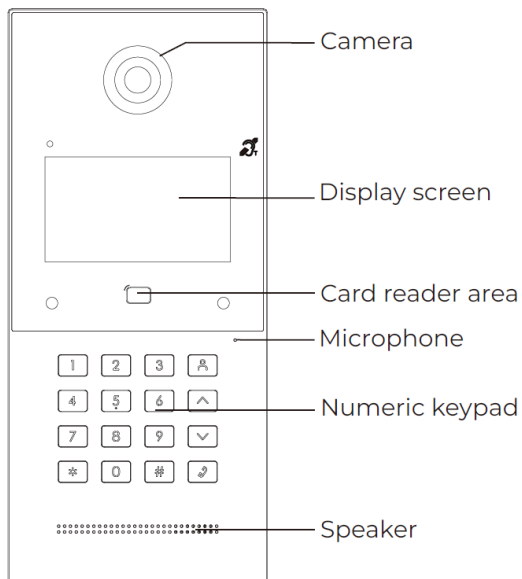

BASIC OPERATION

1. Call and Monitor

1.1 Call Indoor Monitor

In standby mode, press room numbers + #/dial on Door Station to call Indoor Monitor. During the call, press * on Door Station again to end the call. If the call fails or Indoor Monitor is busy, Door Station will make a beep sound.

1.2 Monitor Door Station

Click Monitor icon on Indoor Monitor's homepage to monitor Door Station.

2. Phonebook

Click up or down button to enter phonebook page. You can dial any residents in this phonebook.

3. Unlock

Press #+PIN Code+# to unlock.

4. Concierge

Press concierge button to call Master Station.

5. Facial Recognition

Press * twice to wake up face scan. Facial recognition should be enabled beforehand.

DEVICE SETTING

Connect Door Station and PC to a network switch in the same LAN. You can enter the admin settings of Door Station by pressing # twice and entering default password (123456). This is where you can configure the device.

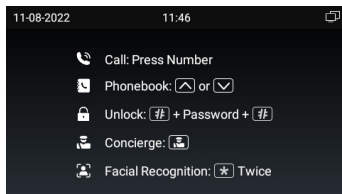

1. Device Settings

Numbers here are basic settings for making a call to Indoor Monitor. For Door Station, the building and unit number should be the same as those in Indoor Monitor. For Villa Station with one button, the building, unit, and room number should be the same as those in Indoor Monitor.

The Index number here is to distinguish different Door Stations when more than one Door Station in one building.

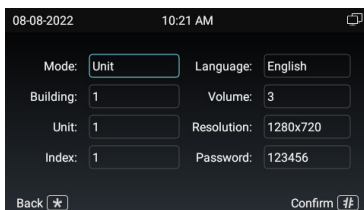

Mode:	Mode for apt., wall or villa (Unit and wall)
Building:	Number of the building (Building range: 1-999);
Unit:	Number of the unit (Unit range: 1-99);
Index:	Number of the Index (Unit range: 1-9);
Language:	16 languages supported (简体中文, English, 繁體中文, עברית, Deutsch, Español, Türk, Tiếng Việt, Nederlands, Português, Polski, Русский, عربي, Français, Italiano, slovenský);
Volume:	Volume of System can be set from 1 to 6;
Resolution:	3 resolutions supported (320 × 240, 640 × 480, 1280

	× 720);
Password:	Administrator password of the Device (Default 123456);

2. Network Settings

The device network can be set to either DHCP or a static IP address. CMS parameters should be configured here when you try to register this device to CMS.

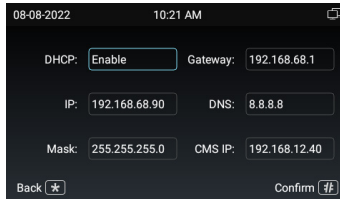

DHCP:	Enable DHCP (Dynamic Host Configuration Protocol) to dynamically distributing network configuration parameters;
IP:	Configure Static IP address to manually distributing network configuration parameters;
Mask:	Subnet mask;
Gateway:	A component that is part of two networks, which use different protocols;
DNS:	Domain Name Server of the device;
CMS IP:	Server address of CMS;

3. Access Settings

You can configure face, PIN code, card, and other settings.

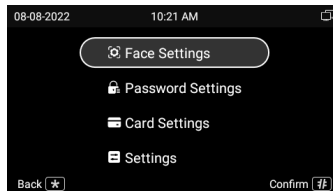

Face Settings:	Manage face recognition;
Password Settings:	Manage PIN codes;
Card Settings:	Manage cards;
Settings:	Manage all other access related settings;

3.1 Face Settings

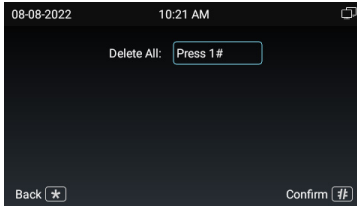

Delete All:	Press 1 + # to delete all face info;
-------------	--------------------------------------

3.2 Password Settings

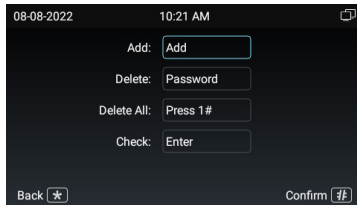

Add:	Press # to add PIN code for different relays;
Delete:	Press PIN code to delete PIN code under this room number;
Delete All:	Press 1 + # to delete all PIN codes;
Check:	Press # to check all PIN codes and related relays;

3.3 Card Settings

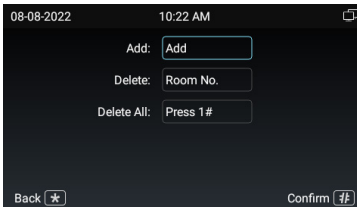

Add:	Press # to add cards;
Delete:	Press room number to delete cards under this room number;
Delete All:	Press 1 + # to delete all cards;

3.4 Settings

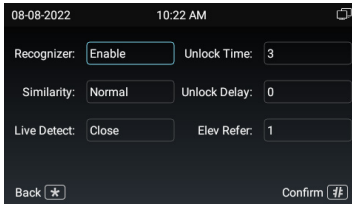

Recognizer:	Enable to use face recognition;
Similarity:	Sensitivity of facial similarity analyzer (Low, normal, high);
Live Detect:	Sensitivity of live detect to prevent picture fraud or video fraud (Close, normal, high);
Unlock Time:	The length of unlock time (1-9s);
Unlock Delay:	The length of unlock delay time (1-9s);
Elev Refer:	The floor Door Station is installed at (Range: -9-99);

4. About System

You can find basic information displayed in About System.



Firmware Version:	Firmware version of the device;
IP:	Current IP address of the device;
MAC:	MAC address of the device;
SIP:	Status of SIP registration of the device;

WEB SETTING

Connect Door Station and PC to a network switch in the same LAN. You can enter the IP address of Door Station in the web browser search bar and log in with the default account (admin) and password (123456). This is where you can configure the device. For getting the IP address, you can search by Remote Upgrade Tool which is installed in the same LAN with the devices.

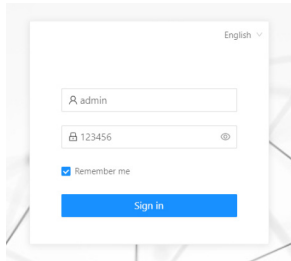

1. General

1.1 General > Information

When you first log in to the web interface, you can find basic information displayed in this dashboard.

Product			
Model	Firmware Version	MAC Address	
904D.1.1.0.35_GA_20221202	904D.1.1.0.35_GA_20221202	BC-F8	
Framework	UI	MCU	
1.9.0.20220815	1.0.35.20221202	1.6.3	

Network		
DHCP	IP Address	Mask
Enabled	192.168.0.105	255.255.255.0
Gateway	DNS	
192.168.0.1	8.8.8.8	

SIP Account	
Account	Status
1178	Register Success
CMS IP	Status
192.168.56.55	Register Failed

Model:	Model of the device;
Firmware Version:	Firmware version of the device;
MAC Address:	MAC address of the device;
Framework:	Framework of the device;
UI:	UI of the device;
MCU:	MCU of the device;
DHCP:	Status of DHCP;
IP Address:	Current IP address of the device;
Mask:	Subnet mask of the device;
Gateway:	Gateway of the device;
DNS:	Domain Name Server of the device;
Account:	SIP account of the device;
Status:	Status of SIP registration of the device;
CMS IP:	IP address of CMS;
Status:	Status of CMS registration;

1.2 General > Basic

Language, resolution and volume of the device can be configured in this column.

The screenshot displays a web-based configuration interface for a device. The top navigation bar includes 'English' and 'Hello, admin'. The left sidebar lists various configuration categories: General, Information, Basic (selected), Time, Password, System, Intercom, Device, Network, SIP, Ring Group, Phonebook, Access, Access Control, Person, and Advanced. The main content area is divided into two sections: 'Basic' and 'Volume'. The 'Basic' section contains 'Language' (set to English) and 'Resolution' (set to 1920x1080), both with dropdown menus, and a 'Save' button. The 'Volume' section features sliders for 'Intercom' and 'System' volume, with a 'Save' button below them.

Language:	16 languages supported (简体中文, English, 繁體中文, עברית, Deutsch, Español, Türk, Tiếng Việt, Nederlands, Português, Polski, Русский, عربي, Français, Italiano, slovenský);
Resolution:	3 resolutions supported (320 × 240, 640 × 480, 1280 × 720);
Intercom:	Volume of Intercom can be set from 1 to 6;
System:	Volume of System can be set from 1 to 6;

1.3 General > Time

Time of the device can be configured. Daylight Saving Time is also supported.

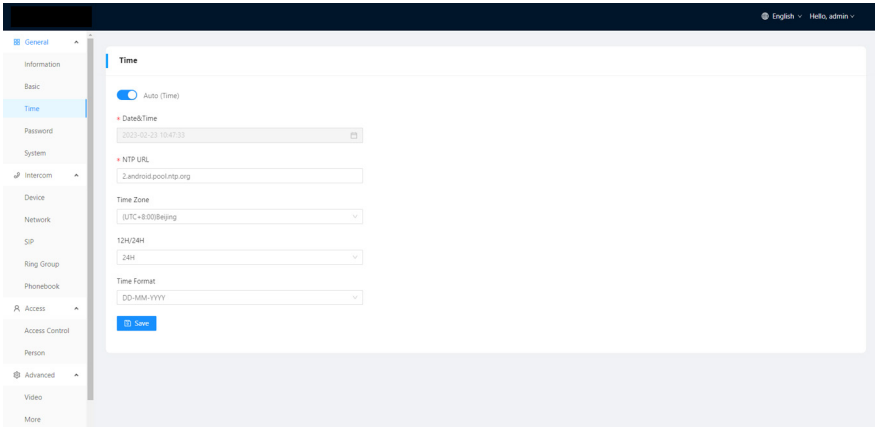

Auto (Time):	Enable to synchronize computer time;
Date&Time:	Date and time can be set manually;
NTP URL:	Network Time Protocol (NTP) is a protocol used to synchronize computer time;
Time Zone:	A region that observes a uniform standard time;
12H/24H:	Select 12H or 24H format to display on the device;
Date Format:	3 time formats supported (YYYY-MM-DD, DD-MM-YYYY, MM-DD-YYYY);

1.4 General > Password

The System password is for the administrator to log in settings on the device while the Web password is for the administrator to log in settings on the web. The default password for both of them is 123456.

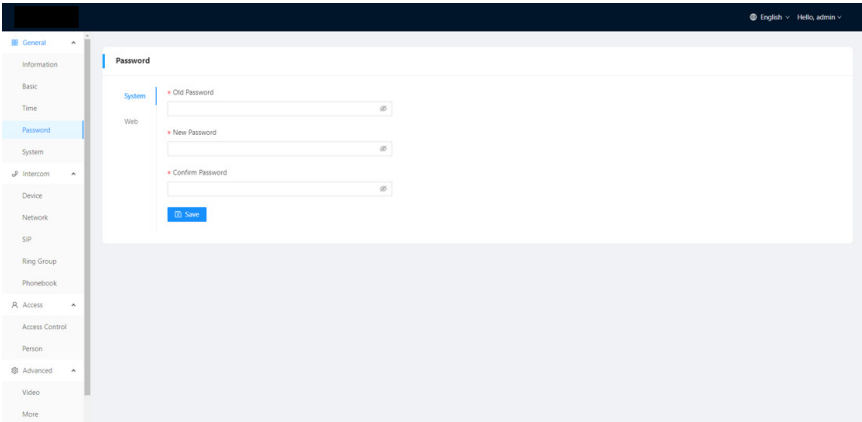

System Old Password:	Current administrator password of the Device (Default 123456);
System New Password:	New administrator password of the Device;
System Confirm Password:	Confirm administrator password of the Device;
Web Old Password:	Current administrator password of the web (Default 123456);
Web New Password:	New administrator password of the web;
Web Confirm Password:	Confirm administrator password of the web;

1.5 General > System

The system column is designed for data backup and restore, firmware upgrade, factory default, device reboot, packet capture, logs capture, and obtaining UI screenshots.



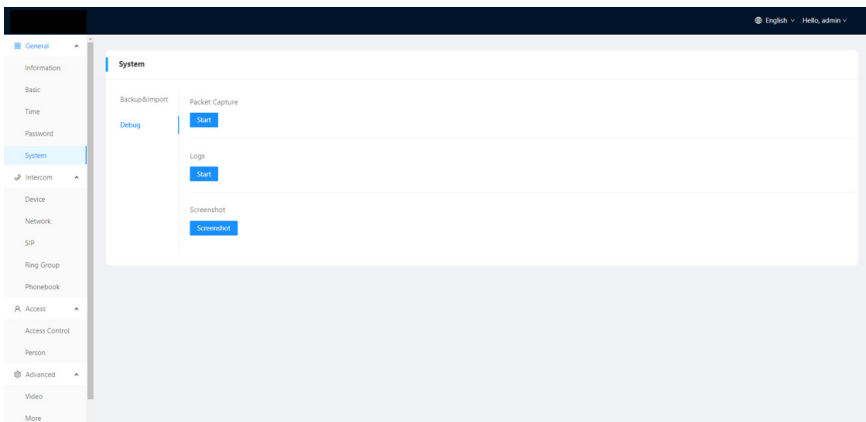

Backup&Restore:	Backup all setting and restore settings;
Upgrade:	Upgrade equipment;
Reset:	Reset to factory settings;
Reboot:	Reboot the device;
Packet Capture:	Capturing packets can help developers reproduce positioning problems;
Logs:	Device logs;
Screenshot:	Screenshot device interface;

2. Intercom

2.1 Intercom > Device

Numbers here are basic settings for making a call to Indoor Monitor. For Door Station, the building and unit number should be the same as those in Indoor Monitor. For Villa Station with one button, the building, unit, and room number should be the same as those in Indoor Monitor.

The device number here is to distinguish different Door Stations when more than one Door Station is in one building.

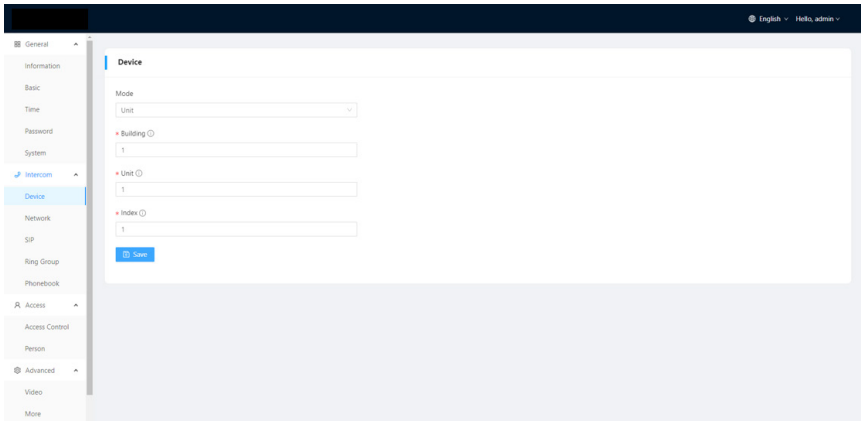

Mode:	Mode for apt. and wall (Unit and wall);
Building:	Number of the building (Range: 1-999);
Unit:	Number of the unit (Range: 1-99);
Index:	Number of the device (Range: 1-9);

2.2 Intercom > Network

The device network can be set to either DHCP or a static IP address. CMS parameters should be configured here when you try to register this device to CMS.

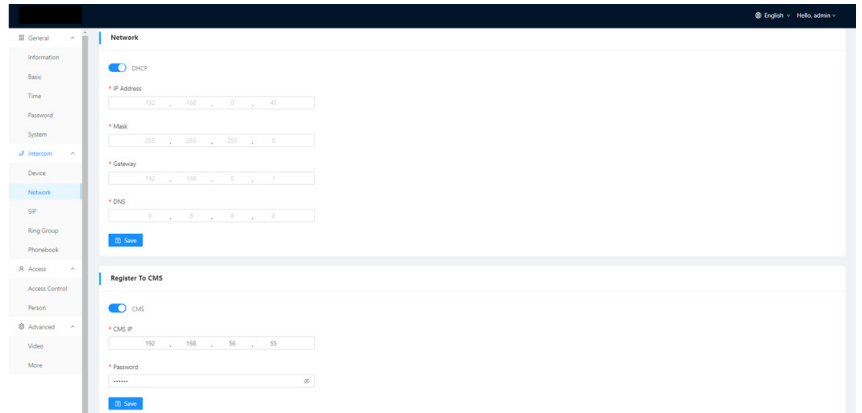

DHCP:	Enable DHCP (Dynamic Host Configuration Protocol) to dynamically distribute network configuration parameters;
-------	---

IP Address:	Configure Static IP address to manually distribute network configuration parameters;
Mask:	Subnet mask;
Gateway:	A component that is part of two networks, which use different protocols;
DNS:	Domain Name Server of the device;
CMS:	Enable to use CMS software to manage devices;
CMS IP:	Server address of CMS;
Password:	Password you set for this device's CMS registration;

2.3 Intercom > SIP

The SIP column concerns SIP registration, Display Name, Register Name, Username, Password, SIP Server Host, Outbound Proxy, Transfer Protocol, Video Payload, etc.

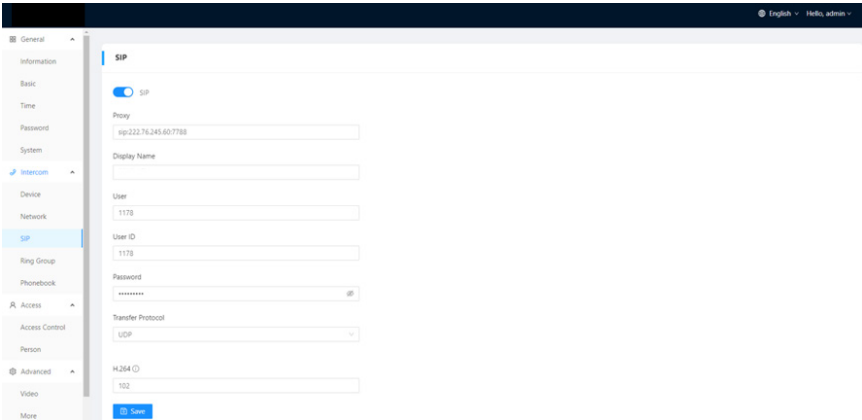

SIP:	Enable to use SIP;
Proxy:	Fill in sip:SIP server's address:port e.g., sip:192.168.68.90:5060;
Display Name:	Display name of SIP;
User:	Register Name of SIP;
User ID:	Username of SIP;
Password:	Password of SIP;
Transfer Protocol:	Transfer Protocol (UDP, TCP, TLS);
H.264:	Video payload range is 96-127;

2.4 Intercom > Ring Group

Ring group is for setting up SIP calls or call mode. Concierge button, the length of the call and ring time can also be configured here.

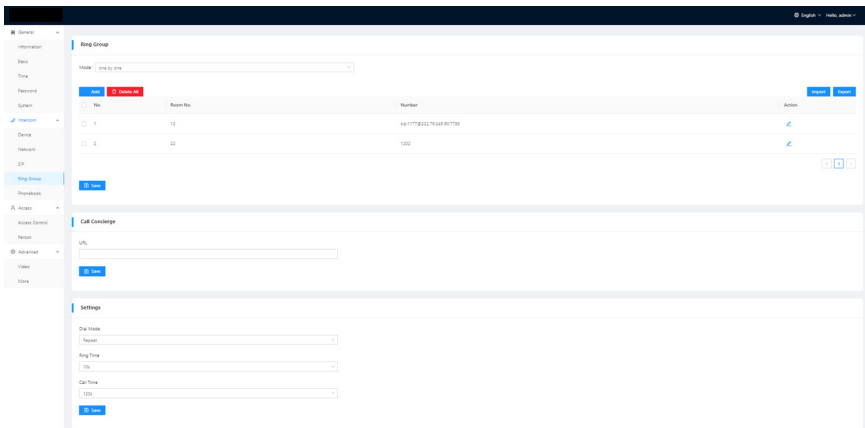

Mode:	2 modes supported (one by one, all at once);
Call Concierge URL:	Fill in the call destination for concierge button or the single button on the device; <ul style="list-style-type: none">● IP call: Fill in sip:IP address, e.g., sip:192.168.68.90;● SIP call: Fill in sip:sip account@SIP server address:port, e.g., sip:101@192.168.68.90:5060;
Dial Mode:	2 dial modes supported (Normal, Repeat);
Ring Time:	The ring will be ended automatically after a period of time (10s, 20s, 35s, 45s, 60s, 90s, 120s)
Call Time:	The call will be ended automatically after a period of time (120s, 300s, 600s, 1200s, 1800s);

2.5 Intercom > Phonebook

All contacts on Door Station can be edited here.

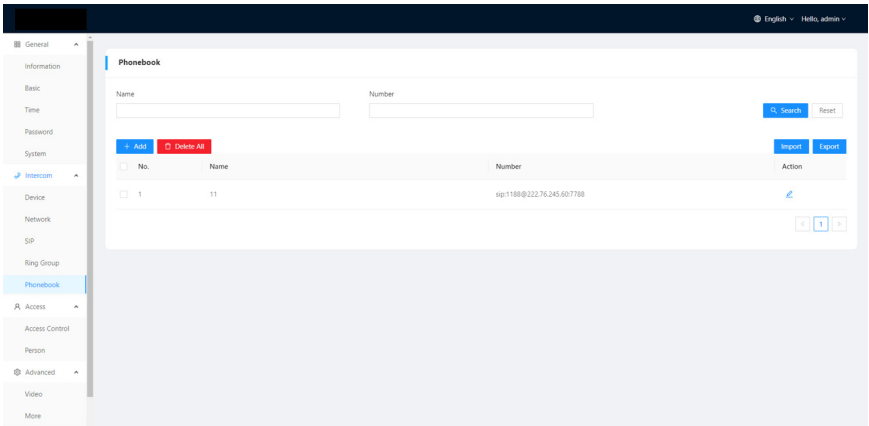

Search:	Fill in text inputs to search;
Reset:	Click reset to clear words in text inputs;
Delete All:	Delete all data on the chart;
Import:	Import all data to the chart;
Export:	Export all data on the chart;

3. Access

3.1 Access > Access Control

Relays, access cards, PIN code can be configured here.

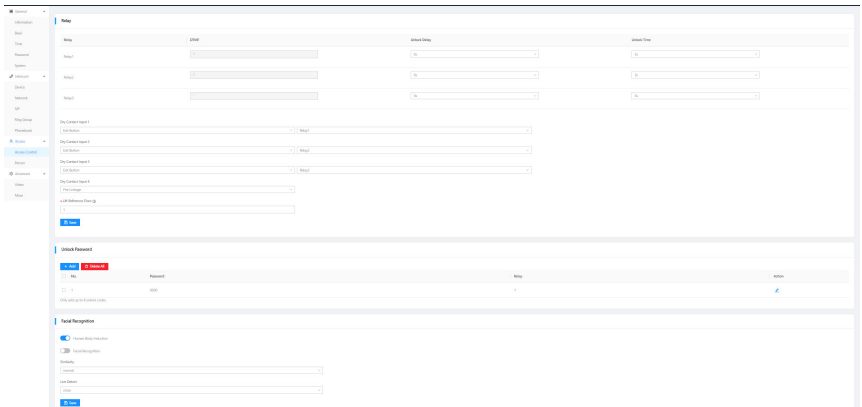

Relay 1-3:	3 relays supported;
DTMF:	Dual-tone multi-frequency signaling (Relay1: #,

	Relay2:0, relay3: *);
Unlock Delay:	The length of unlock delay time (1-9s);
Unlock Time:	The length of unlock time (1-9s);
Dry Contact Input 1-3:	3 modes of dry contact inputs are supported (Exit Button, Door Sensor, Fire Linkage);
Lift Reference Floor:	The floor Door Station is installed at (Range: -9-99);
Master Card:	Click read to add Master card to manage cards;
Unlock Password:	Click to add PIN code or delete all;
Human Body Induction:	Once you approach to Door Station, face scan will be enabled automatically;
Facial recognition:	Enable to use face recognition;
Similarity:	Sensitivity of facial similarity analyzer (Low, normal, high);
Live Detect:	Sensitivity of live detect to prevent picture fraud or video fraud (Close, normal, high);

3.2 Access > Person

Person column is for access authorization.

The screenshot shows the 'Person' management page. At the top, there are search filters for 'Name', 'Room No.', and 'Card No.' with a 'Search' button and a 'Reset' button. Below the filters are two buttons: 'Add' (with a plus icon) and 'Delete All' (with a trash icon). The main area contains a table with the following data:

No.	Name	Room No.	Person Type	Card No.	Relay	Photo	Status	Action
<input type="checkbox"/> 1	household02	3333	Household	None	1	None	Enabled	🔗
<input type="checkbox"/> 2	household01	3333	Household	None	1		Enabled	🔗
<input type="checkbox"/> 3	household03	3333	Household	None	1	None	Enabled	🔗
<input type="checkbox"/> 4	1	1111	Household	None	2,3	None	Enabled	🔗
<input type="checkbox"/> 5	household04	7777	Household	None	1	None	Enabled	🔗
<input type="checkbox"/> 6	household05	7777	Household	None	1	None	Enabled	🔗

At the bottom right of the table, there are pagination controls showing '1' and '2'.

Search:	Fill in text inputs to search;
Reset:	Click reset to clear words in text inputs;
Add:	Add users to Door Station;
Delete All:	Delete all data on the chart;
Export:	Export all data on the chart;

4. Advanced

4.1 Advanced > Video

Real-time video from IP cameras can be obtained by filling in its URL (RTSP). On the talking interface of Indoor Monitor, you can click the little keyboard icon to switch to IP cameras' video. (No.1 on the keyboard stands for Door Station while No.2 to No.5 stands for IP camera)

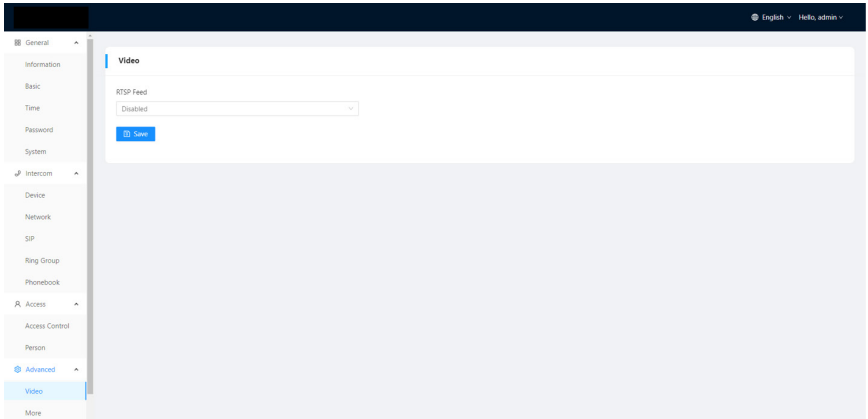

RTSP Feed:	4 IP cameras supported to switch while talking on Indoor Monitor;
URL:	IP camera's URL;

4.2 Advanced > More

More column is for Tamper Alarm and ONU Penetration.

The screenshot shows a configuration interface with a sidebar on the left and a main content area on the right. The sidebar has a menu with categories: Information, Basic, Time, Password, System, Intercom, Device, Network, SP, Ring Group, Phonebook, A Access, Access Control, Person, and Advanced. The 'Advanced' category is expanded, showing 'Video' and 'More'. The main content area has three sections: 'Advertise', 'Tamper', and 'Other'. The 'Advertise' section has a toggle for 'Advertise', a 'URL' input field, and a 'Time (minutes)' dropdown menu set to '10'. The 'Tamper' section has a toggle for 'Tamper Alarm'. The 'Other' section has a toggle for 'ONU Penetration'. A 'Save' button is present in each section.

Advertise:	Enable to advertise on the screen saver of the device;
URL:	Advertise URL;
Time (minutes):	The time length of advertise display (10mins, 20mins, 30mins);
Tamper Alarm:	Enable to use Tamper alarm;
ONU Penetration:	Enable to prevent ONU from banning multicast;

SYSTEM DIAGRAM

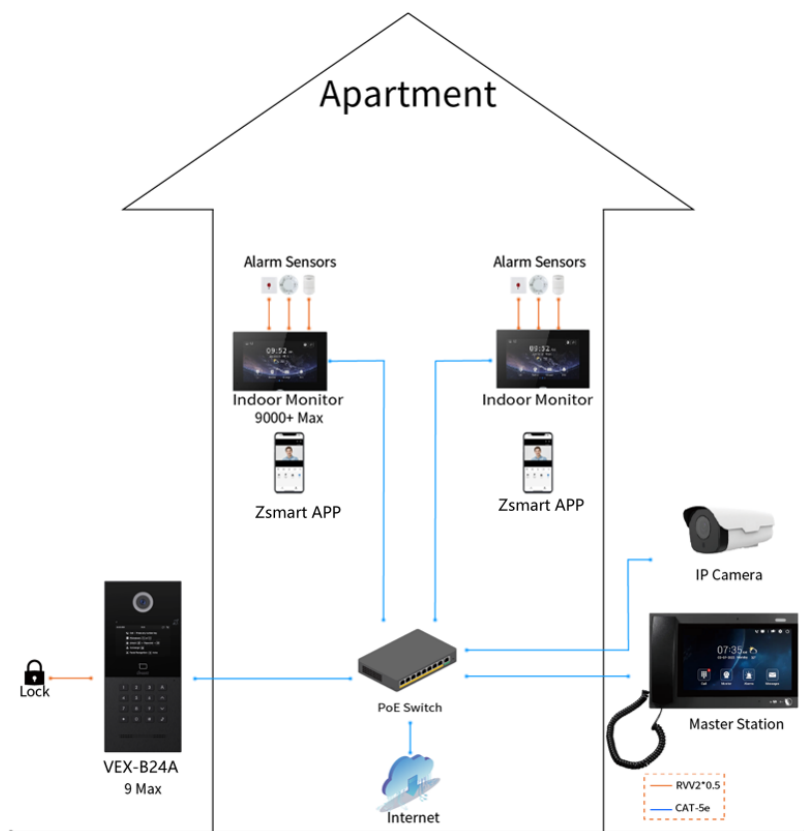

DEVICE WIRING

+12V_IN	1		1	NOS
GND	2	Network(PoE)	2	COM3
WG_DO	3		3	NC3
WG_DI	4		4	NO2
GND	5		5	COM2
INPUT1	6		6	NC2
GND	7		7	NO1
INPUT2	8		8	COM1
GND	9		9	NC1
INPUT3	10		10	GND
GND	11		11	485-
INPUT4	12		12	485+

1. Network (PoE)

Standard RJ45 interface is for the connection with PoE+ switch or other network switch. PSE shall comply with IEEE 802.3at (PoE+) and its output power not less than 30W and its output voltage not be less than 50V.

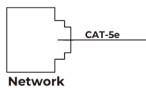

2. Power

The power interface of Door Station connects to 12V DC power.

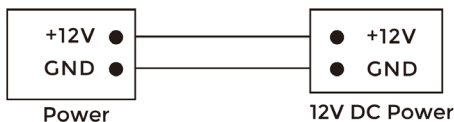

3. Exit/Door-detector/Fire Fighting Linkage

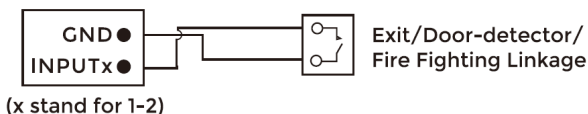

4. RS485/Switching Value Output

Enable to connect equipment with RS485 interface.

Connect to the lock module (an independent power supply is necessary for the lock).

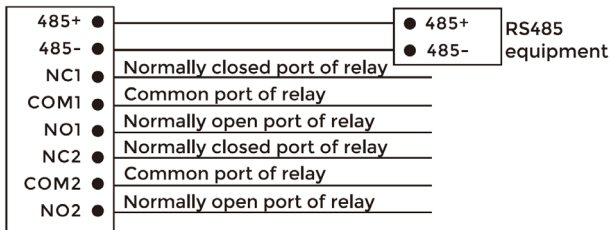

RS485/Switching Value Output

Warning!

1. When connecting to an inductive load device such as a relay or electromagnetic lock, you are recommended to use a diode 1A/400V (included in the accessories) in anti-parallel with the load device to absorb inductive load voltage peaks. The intercom will be better protected in this way.

2. The load current of the relay cannot be greater than 2A. See attached picture for more details.

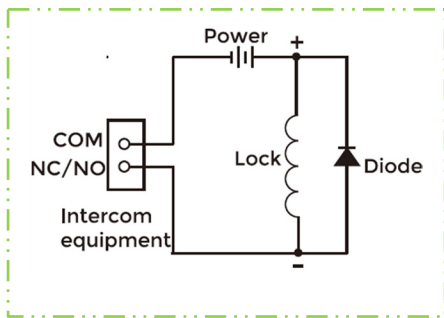

5. Card Reader Interface

The interface can be connected to one IC/ID card reader or be used for reading the information of built-in card reader.

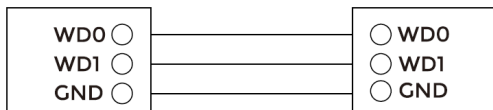

Card Reader Interface

IC/ID Card Reader or Management Device

Note: Door Station can only be connected to one card reader or management device at a time.

INSTALLATION

Surface Mounting-Asian Gang Box

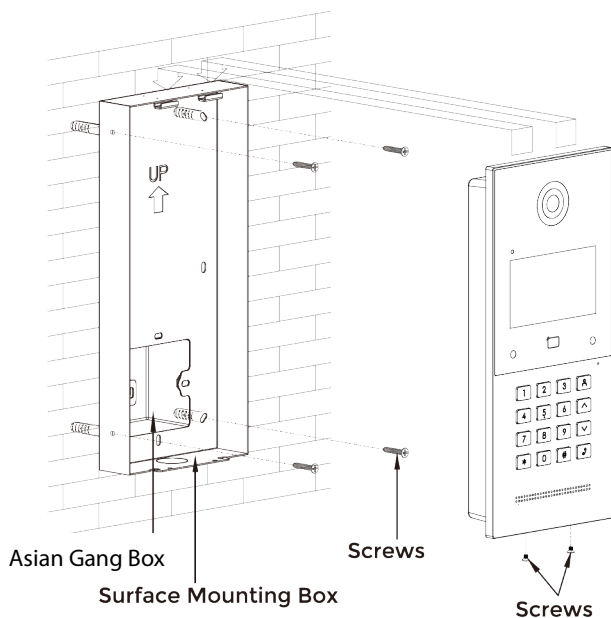

Product size: 133 × 295 × 41 mm
Surface Mounting size: 133 × 295 × 43 mm

Flush Mounting

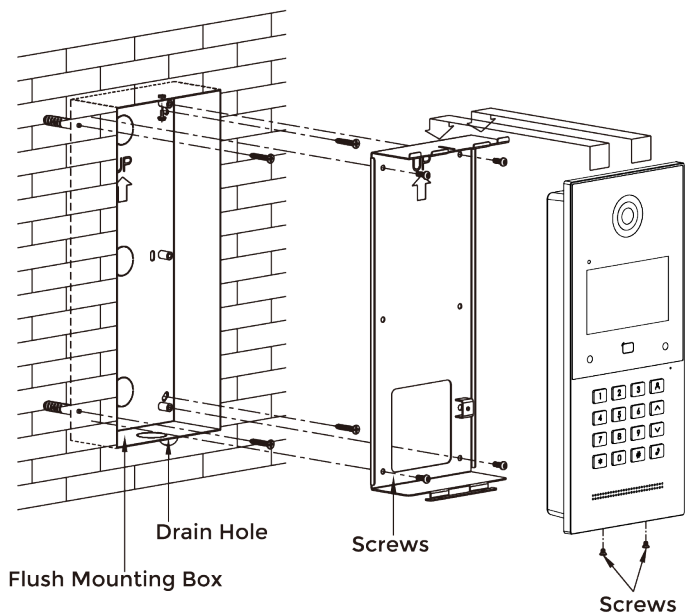

Product size: 133 × 295 × 41 mm
Flush Mounting size: 133 × 295 × 63.5 mm
Mounting hole size: 124 × 289 × 56 mm

Surface Mounting & Rain Hood (Optional)

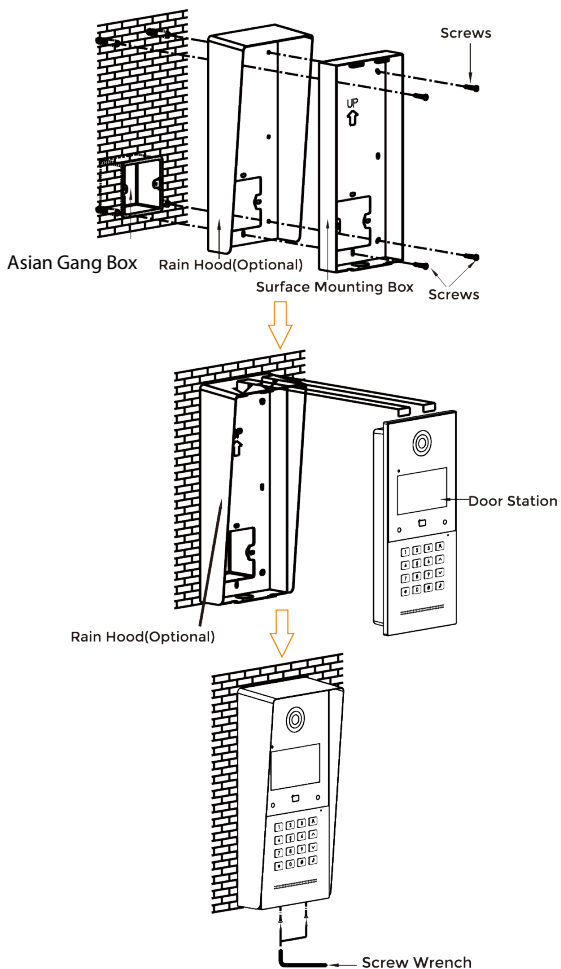

Product size: 133 × 295 × 41 mm
Surface Mounting size: 133 × 295 × 43 mm

Flush Mounting & Rain Hood (Optional)

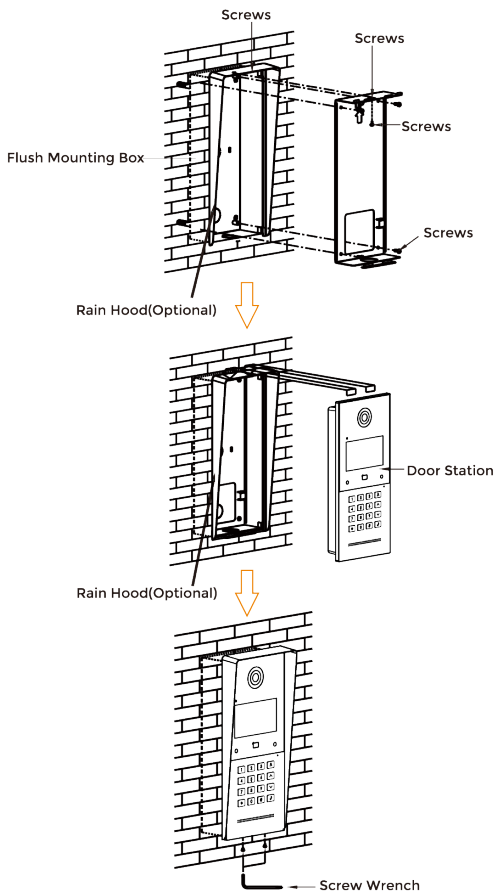

Product size: 133 × 295 × 41 mm
Flush Mounting size: 133 × 295 × 63.5 mm
Mounting hole size: 124 × 289 × 56 mm

Tips:

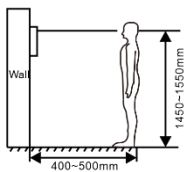

The camera should be 1450~1550mm above the ground. The camera at this height can capture human face perfectly.

TROUBLESHOOTING

The Indoor Monitor cannot start up or power off automatically.

- Check whether it has power-failure, and power it on again

The Indoor Monitor display screen is too dim.

- Check whether the brightness and contrast settings of screen are correct.

No sound during the communication.

- Check whether the Indoor Monitor is set as mute mode, or the volume is set to the lowest.

The Indoor Monitor cannot monitor the Door Station.

- Other user is using the system, so you can use it once he/she finished the operation.

Multimedia files cannot be played normally.

- Check whether the system supports the file format. Please refer to the multimedia setting for details.

No response when clicking Indoor Monitor display screen.

- Press "Unlock" button for 5s, or slowly slide horizontally or vertically on the LCD to make touchscreen calibration. It needs to be calibrated.

Touchscreen responses slowly or cannot make calibration.

- Take down any protective paster, since it may affect identification
- and input for device;
- Ensure the finger is dry and clean when clicking touchscreen;
- Restart the device to clear any temporary software error.

The temperature of device is too high.

- Long-term use leads to high temperature. It's normal and will not affect the device's use life and performance.

SAFETY INSTRUCTION

In order to protect you and others from harm or your device from damage, please read the following information before using the device.

- Do not install the device in the following places:
- Do not install the device in high-temperature and moist environment or the area close to magnetic field, such as the electric generator, transformer or magnet.
- Do not place the device near the heating products such as electric heater or the fluid container.
- Do not place the device in the sun or near the heat source, which might cause discoloration or deformation of the device.
- Do not install the device in an unstable position to avoid the property losses or personal injury caused by the falling of device.

Guard against electric shock, fire and explosion:

- Do not use damaged power cord, plug or loose outlet.
- Do not touch the power cord with wet hand or unplug the power cord by pulling.
- Do not bend or damage the power cord.
- Do not touch the device with wet hand.
- Do not make the power supply slip or cause the impact.
- Do not use the power supply without the manufacturer's approval.
- Do not have the liquids such as water go into the device.

Clean Device Surface

- Clean the device surfaces with soft cloth dipped in some water, and then rub the surface with dry cloth.

Other Tips

- In order to prevent damage to the paint layer or the case, please do not expose the device to chemical products, such as the diluent, gasoline, alcohol, insect-resist agents, opacifying agent and insecticide.
- Do not knock on the device with hard objects.
- Do not press the screen surface. Overexertion might cause flopover or damage to the device.
- Please be careful when standing up from the area under the device.
- Do not disassemble, repair or modify the device at your own discretion.
- The arbitrary modification is not covered under warranty. When any repair required, please contact the customer service center.
- If there is abnormal sound, smell or fume in the device, please unplug the power cord immediately and contact the customer service center.
- When the device isn't used for a long time, the adaptor and memory card can be removed and placed in dry environment.
- When moving, please hand over the manual to new tenant for proper usage of the device.

FCC Warning

This device complies with Part 15 of the FCC Rules. Operation is subject to the following two conditions:

(1) This device may not cause harmful interference, and (2) this device must accept any interference received, including interference that may cause undesired operation.

NOTE 1: This equipment has been tested and found to comply with the limits for a Class B digital device, pursuant to part 15 of the FCC Rules. These limits are designed to provide reasonable protection against harmful interference in a residential installation. This equipment generates uses and can radiate radio frequency energy and, if not installed and used in accordance with the instructions, may cause harmful interference to radio communications. However, there is no guarantee that interference will not occur in a particular installation. If this equipment does cause harmful interference to radio or television reception, which can be determined by turning the equipment off and on, the user is encouraged to try to correct the interference by one or more of the following measures:

- Reorient or relocate the receiving antenna.
- Increase the separation between the equipment and receiver.
- Connect the equipment into an outlet on a circuit different from that to which the receiver is connected.
- Consult the dealer or an experienced radio/TV technician for help.

NOTE 2: Any changes or modifications to this unit not expressly approved by the party responsible for compliance could void the user's authority to operate the equipment.

RF exposure statement

This equipment complies with the FCC radiation exposure limits set forth for an uncontrolled environment. This transmitter must not be co-located or operating in conjunction with any other antenna or transmitter.

ZKTeco Industrial Park, No. 32, Industrial Road,

Tangxia Town, Dongguan, China.

Phone : +86 769 - 82109991

Fax : +86 755 - 89602394

www.zkteco.com

