

User Manual

X100 & X101

Date: 2025.06.25

Doc Version: 1.0

English

Thank you for choosing our product. Please read the instructions carefully before operation. Follow these instructions to ensure that the product is functioning properly. The images shown in this manual are for illustrative purposes only.



For further details, please visit our Company's website www.zkteco.com.

Copyright © 2025 ZKTECO CO., LTD. All rights reserved.

Without the prior written consent of ZKTeco, no portion of this manual can be copied or forwarded in any way or form. All parts of this manual belong to ZKTeco and its subsidiaries (hereinafter the "Company" or "ZKTeco").

Trademark

ZKTeco is a registered trademark of ZKTeco. Other trademarks involved in this manual are owned by their respective owners.

Disclaimer

This manual contains information on the operation and maintenance of the ZKTeco equipment. The copyright in all the documents, drawings, etc. in relation to the ZKTeco supplied equipment vests in and is the property of ZKTeco. The contents hereof should not be used or shared by the receiver with any third party without express written permission of ZKTeco.

The contents of this manual must be read as a whole before starting the operation and maintenance of the supplied equipment. If any of the content(s) of the manual seems unclear or incomplete, please contact ZKTeco before starting the operation and maintenance of the said equipment.

It is an essential pre-requisite for the satisfactory operation and maintenance that the operating and maintenance personnel are fully familiar with the design and that the said personnel have received thorough training in operating and maintaining the machine/unit/equipment. It is further essential for the safe operation of the machine/unit/equipment that personnel has read, understood and followed the safety instructions contained in the manual.

In case of any conflict between terms and conditions of this manual and the contract specifications, drawings, instruction sheets or any other contract-related documents, the contract conditions/documents shall prevail. The contract specific conditions/documents shall apply in priority.

ZKTeco offers no warranty, guarantee or representation regarding the completeness of any information contained in this manual or any of the amendments made thereto. ZKTeco does not extend the warranty of any kind, including, without limitation, any warranty of design, merchantability or fitness for a particular purpose.

ZKTeco does not assume responsibility for any errors or omissions in the information or documents which are referenced by or linked to this manual. The entire risk as to the results and performance obtained from using the information is assumed by the user.

ZKTeco in no event shall be liable to the user or any third party for any incidental, consequential, indirect, special, or exemplary damages, including, without limitation, loss of business, loss of profits, business interruption, loss of business information or any pecuniary loss, arising out of, in connection with, or relating to the use of the information contained in or referenced by this manual, even if ZKTeco has been advised of the possibility of such damages.

This manual and the information contained therein may include technical, other inaccuracies or typographical errors. ZKTeco periodically changes the information herein which will be incorporated into new additions/amendments to the manual. ZKTeco reserves the right to add, delete, amend or modify the information contained in the manual from time to time in the form of circulars, letters, notes, etc. for better operation and safety of the machine/unit/equipment. The said additions or amendments are meant for improvement /better operations of the

machine/unit/equipment and such amendments shall not give any right to claim any compensation or damages under any circumstances.

ZKTeco shall in no way be responsible (i) in case the machine/unit/equipment malfunctions due to any non-compliance of the instructions contained in this manual (ii) in case of operation of the machine/unit/equipment beyond the rate limits (iii) in case of operation of the machine and equipment in conditions different from the prescribed conditions of the manual.

The product will be updated from time to time without prior notice. The latest operation procedures and relevant documents are available on <http://www.zkteco.com>

If there is any issue related to the product, please contact us.

ZKTeco Headquarters

Address ZKTeco Industrial Park, No. 32, Industrial Road,
Tangxia Town, Dongguan, China.

Phone +86 769 - 82109991

Fax +86 755 - 89602394

For business related queries, please write to us at: sales@zkteco.com.

To know more about our global branches, visit www.zkteco.com.

About the Company

ZKTeco is one of the world's largest manufacturer of RFID and Biometric (Fingerprint, Facial, Finger-vein) readers. Product offerings include Access Control readers and panels, Near & Far-range Facial Recognition Cameras, Elevator/floor access controllers, Turnstiles, License Plate Recognition (LPR) gate controllers and Consumer products including battery-operated fingerprint and face-reader Door Locks. Our security solutions are multi-lingual and localized in over 18 different languages. At the ZKTeco state-of-the-art 700,000 square foot ISO9001-certified manufacturing facility, we control manufacturing, product design, component assembly, and logistics/shipping, all under one roof.

The founders of ZKTeco have been determined for independent research and development of biometric verification procedures and the productization of biometric verification SDK, which was initially widely applied in PC security and identity authentication fields. With the continuous enhancement of the development and plenty of market applications, the team has gradually constructed an identity authentication ecosystem and smart security ecosystem, which are based on biometric verification techniques. With years of experience in the industrialization of biometric verifications, ZKTeco was officially established in 2007 and now has been one of the globally leading enterprises in the biometric verification industry owning various patents and being selected as the National High-tech Enterprise for 6 consecutive years. Its products are protected by intellectual property rights.

About the Manual

This manual introduces the operations of X100 & X101 product.

All figures displayed are for illustration purposes only. Figures in this manual may not be exactly consistent with the actual products.

Table of Contents

- 1 INTRODUCTION 7**
 - 1.1 FEATURES 7
 - 1.2 SPECIFICATIONS 7
 - 1.3 CARTON INVENTORY 10
- 2 INSTALLATION 10**
 - 2.1 WIRING 11
 - 2.2 SOUND AND LIGHT INDICATION 12
 - 2.3 BASIC CONFIGURATION 12
 - 2.3.1 ENTER AND EXIT PROGRAM MODE 12
 - 2.3.2 SET MASTER CODE 12
 - 2.3.3 SET THE WORKING MODE 13
- 3 STANDALONE MODE 13**
 - 3.1 CONNECTION DIAGRAM COMMON POWER SUPPLY 13
 - 3.2 ACCESS CONTROL POWER SUPPLY 15
 - 3.3 PROGRAMMING 15
 - 3.4 TIPS for PIN SECURITY (ONLY VALID for 6 DIGITS PIN) 17
 - 3.5 ADD VISITOR USERS (VALID for CARD / PIN USERS) 17
 - 3.6 CHANGE PIN USERS 18
 - 3.7 SET RELAY CONFIGURATION 19
 - 3.8 SET ACCESS MODE 19
 - 3.9 SET STRIKE-OUT ALARM 20
 - 3.10 SET AUDIBLE AND VISUAL RESPONSE 20
 - 3.11 MASTER FINGERPRINT / CARD USAGE 21
 - 3.12 USERS OPERATION & RESET to FACTORY DEFAULT 21
- 4CONTROLLER MODE 22**

- 4.1 CONNECTION DIAGRAM 23
- 4.2 SET WIEGANG INPUT FORMATS 23
- 4.3 PROGRAMMING 24
- 4.4 THE DEVICE CONNECTED with KEYPAD READER 24

- 5 WIEGAND READER MODE 25**

 - 5.1 CONNECTION DIAGRAM 25
 - 5.2 SET WIEGANG OUTPUT FORMATS 26

- 6 INSTALLATION 26**

 - 6.1 COLLECTION CARD MODE 26
 - 6.2 USER INFORMATION TRANSFER (VALID for CARDS / PIN USERS) 27
 - 6.3 SET TRANSFERRING on MASTER UNIT 28

1 INTRODUCTION

The device is a single door multifunction standalone access controller or a Wiegand output reader. It uses Atmel MCU assuring stable performance.

The operation is very user-friendly, and low-power circuit makes it long service life.

The device can be made with Bluetooth version or with WIFI version.

1.1 Features

- Capacitive fingerprint sensor, Touch key
- Waterproof, conforms to IP66
- PIN length: 4~6 digits
- EM card, Mifare cards optional
- EM card: Wiegand 26-44 bits input & output
- Mifare card: Wiegand 26~44bits, 56bits, 58bits input & output
- Can be used as Wiegand reader with LED & buzzer output
- Card block enrollment
- Tri-color LED status display
- Integrated alarm & buzzer output
- Pulse mode, Toggle mode
- User data can be transferred (except fingerprint users)
- Built-in light dependent resistor (LDR) for anti tamper
- Backlit keypad, can set automatic OFF after 20 seconds

1.2 Specifications

Model	X100 / X101
--------------	-------------

Display	N/A
Authentication method	Fingerprint / Card / PIN Code (Physical Touch Keypad)
User Capacity	10,500 (1:N) (Standard)
Card Capacity	10,000 (1:N) (Standard)
Fingerprint Template Capacity	500 (1:N) (Standard)
Transaction Capacity	N/A
Max. User Password Length	Support 4 to 10 Digit number (Factory Default: 4 digits)
Biometric Verification Speed	less than 0.3 sec (Fingerprint)
False Acceptance Rate (FAR) 96	FAR ≤ 0.0001%
False Rejection Rate (FRR) 96	FRR ≤ 0.01%;
Card Type	ID Card @125 kHz (Standard) IC Card @13.56 MHz (Optional)
Communication	Wiegand (26-44bits Input / Output)*1 Electric Lock*1, Door Sensor*1, Exit Button*1, Doorbell*1
Standard Functions	Access Control, Buzzer, Multiple Verification Methods, LED Status Indicators: Orange: Programming Green: Verification successful Red: Standby, Verification Fail 3 Beeps Operation Error: 3 Beeps; No Indicator

Power supply	DC 12V0.15A
Operating Temperature	-25° °C to 60°C
Operating Humidity	10% to 90% RH (Non-condensing)
Dimensions	X100:140mm*45mm*15mm(L*W*H) X101:115mm*70 mm*15mm (L*W*H)
Gross Weight	X100:0.21Kg X101:0.23Kg
Net Weight	X100:0.105Kg X101:0.140Kg
Supported Software	N/A
Installation	Wallmount
Housing Material	ABS
Ingress Protection Rating	IP66 (waterproof and dustproof)
Certifications	ISO14001, ISO9001, CE, ROHS

1.3 Carton Inventory

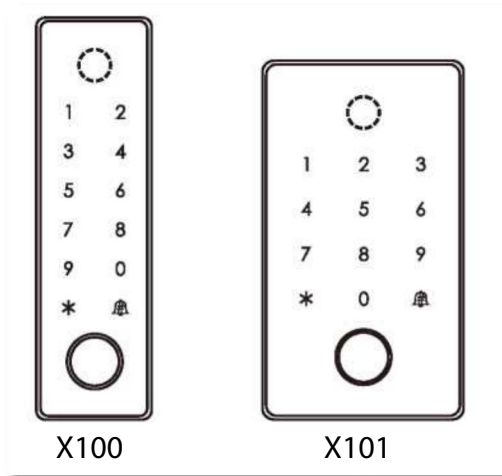

2 INSTALLATION

- Remove the back cover from the unit
- Drill 2 holes(A,C) on the wall for the screws and one hole for the cable
- Knock the supplied rubber bungs to the screw holes(A,C)
- Fix the back cover firmly on the wall with 4 flat head screws
- Thread the cable through the cable hole(B)
- Attach the unit to the back cover

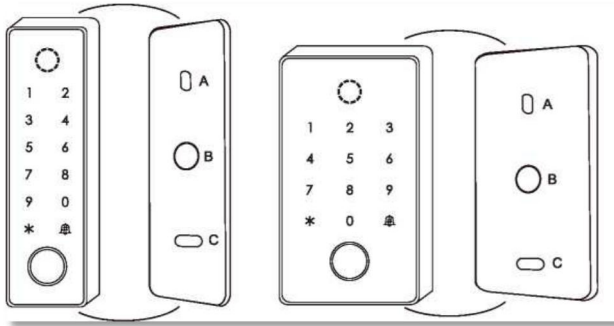

2.1 Wiring

Wire Color	Function	Notes
Basic Standalone Wiring		
Red	DC+	12V DC Power Input
Black	GND	Negative Pole of DC Power Input
Blue	Relay NO	Normally Open Relay Output (install diode provided)
Purple	Relay Common	Common Connection for Relay Output
Orange	Relay NC	Normally Closed Relay Output (Install diode provided)
Yellow	OPEN	Request to Exit(REX) Input
Pass-Through Wiring (Wiegand)		Reader or Controller)
Green	Data0	Wiegand Output (Pass-through) Data 0
White	Data 1	Wiegand Output (Pass-through) Data 1
WIFI Version with Doorbell		
Grey	Doorbell +	Contact for Doorbell
Brown	Doorbell -	Contact for Doorbell

2.2 Sound and Light Indication

Operation Status	LED	Buzzer
Stand by	Red light bright	
Enter into programming mode	Red light shines	One beep
In the programming mode	Orange light bright	One beep
Operation error		Three beeps
Exit from the Programming mode	Red light bright	One beep
Open lock	Green light bright	One beep
Alarm	Red light Shines quickly	Beeps

2.3 Basic Configuration

2.3.1 Enter and Exit Program Mode

Programming Step	Keystroke Combination
Enter Program Mode	•k (MasterCode)# (Factory default is 123456)
Exit Program Mode	*

2.3.2 Set Master Code

Programming Step	Keystroke Combination
1. Enter Program Mode	* (MasterCode)#
2. Update Master Code	0 (New Master Code) # (Repeat New Master Code)# (Master code is any 6 digits)

3. Exit Program Mode	
----------------------	--

2.3.3 Set the Working Mode

Notes: The device has 3 working modes: Standalone Mode, Controller Mode, Wiegand Reader Mode, choose the mode you use. (Factory default is Standalone Mode / Controller Mode)

Programming Step	Keystroke Combination
1. Enter Program Mode	-k (MasterCode)#
2. Standalone / ControllerMode OR 2. Wiegand Reader Mode	77# (Factory default) 78#
3. Exit	*

3 STANDALONE MODE

The device can work as Standalone Access Control for single door. (Factory default mode) — 77#

3.1 Connection Diagram Common Power Supply

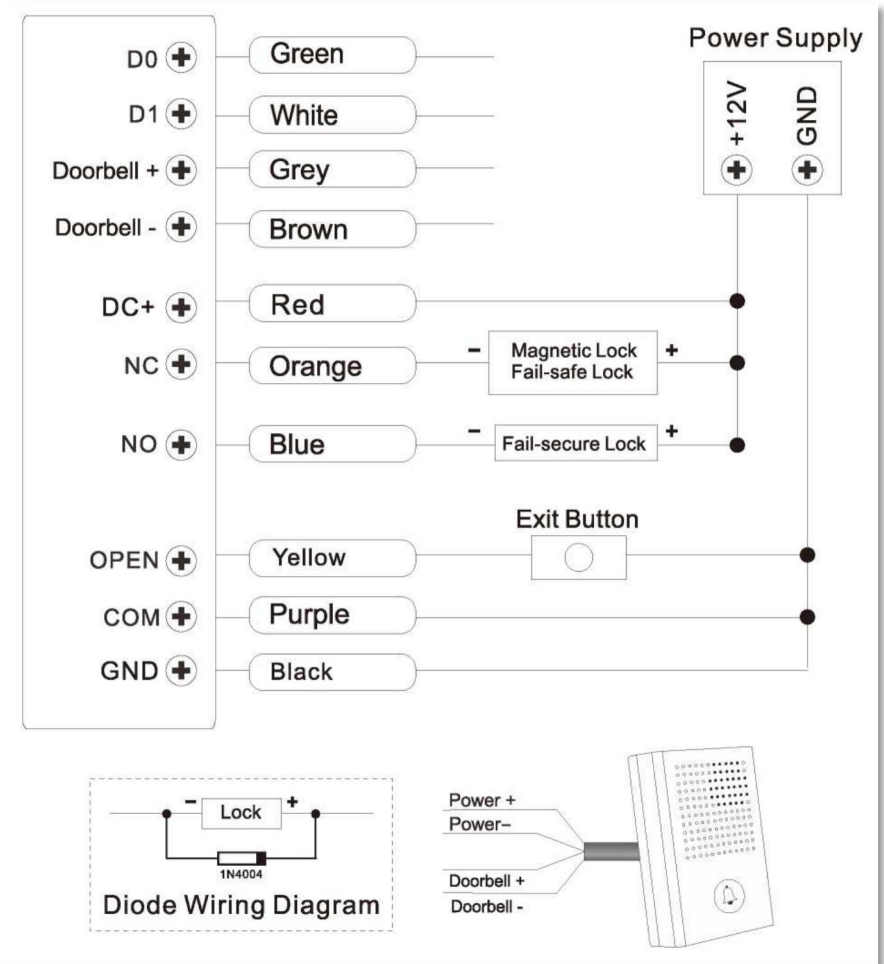

Attention:

Install a 1N4004 or equivalent diode is needed when use a common power supply, or the keypad might be damaged. (1N4004 is included in the packing)

3.2 Access Control Power Supply

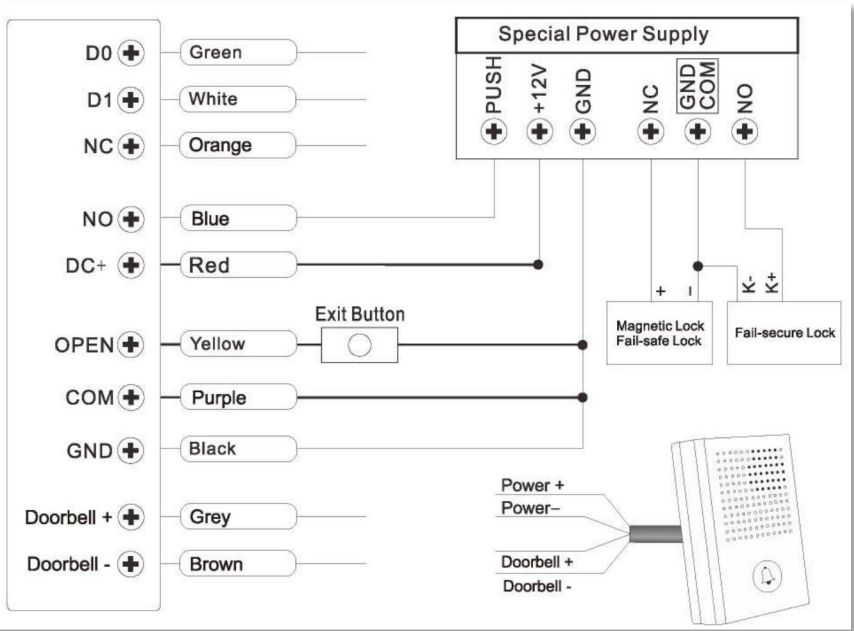

3.3 Programming

Programming will be vary depending on access configuration. Follow the instructions according to your access configuration.

Notes:

- **User ID number** Assign a user ID to the access fingerprint / card / PI N in order to track it.
- **User ID number:**
The Common Card / PIN User ID: 1-9990 Visitor User
ID: 9991 ~ 10000

Fingerprint User ID: 10001 ~ 10500

IMPORTANT: User IDs do not have to be proceeded with any leading zeros. Recording of User ID is critical. Modifications to the user require the User ID be available.

- **Proximity Card:**

Proximity Card: EM card / Mifare cards

- **PIN:** Can be any 4~6 digits.

(Fingerprint user ID: 10001-10499; PIN/ Card user ID: 1-9990; PIN length: 4 ~6 digits)

Programming Step	Keystroke Combination
1. Enter Program Mode	-k (MasterCode)#
Add Fingerprint User	
2. Using Auto ID (Allows the device to assign Fingerprint to next available User ID number) OR 2. Select Specified ID (Allows Master to define a specific User ID to associate the fingerprint to)	<p>1 (Fingerprint) (Repeat Fingerprint) (Repeat Fingerprint again) Fingerprints can be added continuously.</p> <p>1 (User ID) # (Fingerprint) (Repeat Fingerprint) (Repeat Fingerprint again) Fingerprints can be added continuously.</p>
Add Card User	
2. Using Auto ID (Allows the device to assign Card to next available User ID number) OR 2. Select Specific ID (Allows Master to define a specific User ID to associate the card to) OR 2. Add Card: Block Enrollment (Allows manager to add up to 200 cards to the Reader in a single step) Takes 3 minutes	<p>1 (Read Card)/(Input 8/10/17 Digits Card Number)# The cards can be added continuously.</p> <p>1 (User ID) # (Read Card) / ([Fingerprint Icon] at 8/16/17 Digits Card Number) # 1 (User ID) # (Card Quantity) # (The First Card 8/10/17 Digits Number)# Cards' number must be consecutive; Card quantity = number of cards to be</p>

to program.	enrolled.
Add PIN User	
2. Select Specific ID (Allows manager to define a specific User ID to associate the PIN to)	1 (User ID)# (PIN)#
3. Exit	*

3.4 Tips for PIN Security (Only valid for 6 digits PIN):

For higher security we allow you to hide your correct PIN with other numbers up to a max of 10 digits.

Example PIN: 123434

You could use *(123434)* or *(123434)

("*" can be any numbers from 0~9)

Add Master Fingerprint (By Specified ID:10500)

Programming Step	Keystroke Combination
1. Enter Program Mode	*(MasterCode)#
1. Add Master Fingerprint	1 (10500) # (Fingerprint) (Repeat Fingerprint) (Repeat Fingerprint again)
3. Exit	*

3.5 Add Visitor Users (Valid for Card/ PIN Users)

(User ID number is 9991-10000 PIN length: 4~6 digits)

There are 10 groups Visitor PIN/card available, the users can be specified up to 10 times of usage, after a certain number of times, i.e. 5 times, the PIN/card become invalid automatically.

Programming Step	Keystroke Combination
1. Enter Program Mode	★ (Master Code) #

2. Add Card	1 (User ID) # (0~9) # (Read Card) /
OR	(Input 8/10/17 Digits Card Number)#
2. Add PIN	1 (UserID)#(0~9)#(PIN)# (0~9 means times of usage, 0=10 times)
3. Exit	*

3.6 Change PIN Users (PIN length: 4~6 digits)

Programming Step	Keystroke Combination
Note: Below is done outside programming mode, users can undertake this themselves	
Change PIN	* (User ID) # (Old PIN) # (New PIN) # (Repeat New PIN)#

Programming Step	Keystroke Combination
1. Enter Program Mode	* (MasterCode)#
2. Delete User- By Fingerprint/ Card	2 (Input Fingerprint)/ (Read Card)# The users can be deleted continuously.
OR	
2. Delete User - By ID number	2 (User ID)#
OR	
2. Delete User - By Card number	2 (input 8/10/17Digits Card Number)#
OR	
2. Delete ALL Users	2 (Master Code)#
3. Exit	*

3.7 Set Relay Configuration

The relay configuration sets the behaviour of the output relay on activation.

Programming Step	Keystroke Combination
1. Enter Program Mode	★ (Master Code) #
2. Pulse Mode OR 2. Toggle Mode	3 (1 ~99) # (factory default) The relay time is 1 -99 seconds. (Default is 5 seconds) 30# Sets the relay to ON/OFF Toggle mode
3. Exit	*

3.8 Set Access Mode

For Multi user access mode, the interval time of reading can not exceed 5 seconds, or else, the device will exit to standby automatically.

Programming Step	Keystroke Combination
1. Enter Program Mode	★ (Master Code) #
2 Card Access	40#
OR	
2 PIN Access	41 #
OR	
2 FingerprintAccess	42#
OR	4 3 (2~9) # (Only after 2~9 valid users, the door be opened)
2 Multi User Access OR 2 Fingerprint or Card or PIN Access	43# (factory default)
3. Exit	*

3.9 Set Strike-out Alarm

The strike-out alarm will engage after 10 failed entry attempts (Factory is OFF). It can be set to deny access for 10 minutes after engaging or disengage only after entering a valid Fingerprint/ card/ PIN or Master code/ fingerprint/ card.

Programming Step	Keystroke Combination
1. Enter Program Mode	* (MasterCode)#
2. Strike-Out OFF OR 2. Strike-Out ON OR 2. Strike-Out ON (Alarm) Set Alarm Time	<p>6 0# (factorydefault)</p> <p>61# Access will be denied for 10 minutes (Exit button is still workable)</p> <p>62# 5 (0 ~ 3) # (factory default is 1 minute) Enter Master Code # or Master Fingerprint / Card or valid user fingerprint / card / PIN to silence</p>
3. Exit	*

The function of **Set Alarm Time** also apply for anti-tamper alarm

3.10 Set Audible and Visual Response

Programming Step	Keystroke Combination
1. Enter Program Mode	★ (Master Code) #
2. Disable Sound	70#
Enable Sound	71# (factory default)
OR	
2. LED Always OFF	72#
LED Always ON	7 3# (factory default)

<p>OR</p> <p>2. Keypad Backlit Always OFF Keypad Backlit Always ON Keypad Backlit Automatic OF</p>	<p>74# 75# 7 6# (factory default) Automatic OFF after 20 seconds, it will go ON by pressing any key (this key isn't taken into consideration)</p>
<p>3. Exit</p>	<p>*</p>

3.11 Master Fingerprint / Card Usage

<p>Using Master Fingerprint/ Card to add and delete users</p>	
<p>Add Fingerprint/ Card/ PIN Users</p>	<p>1 ■ Input (Master Fingerprint / Card) 2. Input (Fingerprint three times) or (Card) or (User ID#PIN#) Repeat step 2 for additional users 3. Input (Master Fingerprint / Card) again</p>
<p>Delete Fingerprint/ Card/ PIN Users</p>	<p>1.Input (Master Fingerprint/ Card Twice within 5s) 2. Input (Fingerprint) or (Card) or (User ID#) Repeat step 2 for additional users 3. Input (Master Fingerprint / Card) again</p>

3.12 Users Operation & Reset to Factory Default

- **Open the door:** Read valid user fingerprint or user card or input valid user PIN #
- **Remove Alarm:** Enter Master Code # or Master Fingerprint/ Card or valid user fingerprint / card / PIN

- **To reset to factory default & Add Master Card:** Power off, press the Exit Button, hold it and power on, there will be two beeps, then release the exit button, the LED light turns into yellow, then read any 125KHz EM card/ 13.56MHz Mifare card, the LED will turn into red, means reset to factory default successfully. Of the card reading, it is the Master Card.

Remarks:

© If no Master Card added, must press the Exit Button for at least 5 seconds before release.(this will make the previous registered Master Card invalid) ②
Reset to factory default, the user' s information is still retained.

4 CONTROLLER MODE

The device can work as Controller, connected with the external Wiegand reader.
(Factory default mode) — 77#

4.1 Connection Diagram

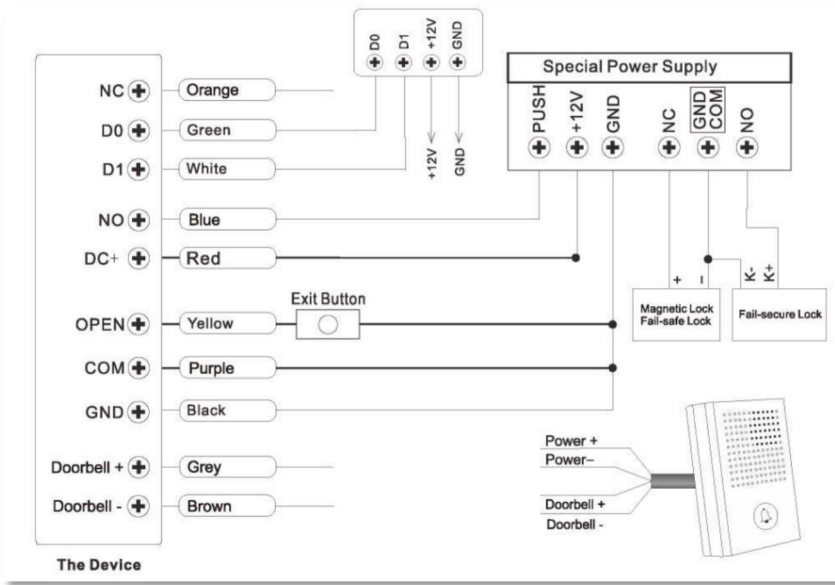

Attention: Install a **1N4004** or equivalent diode is needed when use a common power supply, or the reader might be damaged. (**1N4004** is included in the packing)

4.2 Set Wiegand Input Formats

Please set the Wiegand input formats according to the Wiegand output format of the external Reader.

Programming Step	Keystroke Combination
1. Enter Program Mode	rk (MasterCode)#
2. Wiegand Input Bit	<p>For EM Card: 8 (26-44)# (factory default is 26bits)</p> <p>For Mifare Card: 8 0 (26-44,56,58) # (factory default is 34bits)</p>

3. Disable Parity Bit Enable Parity Bit	80# 81# (factory default)
4. Exit	*

Note: For connecting Wiegand readers with 32,40,56 bits output, need disable parity bits.

4.3 Programming

- **Basic Programming is the same as Standalone Mode**
- **There are some exceptions for your attention:**

The device Connected with External Card Reader

-If EM/Mifare card reader: users can be added/deleted on either the device or external reader.

-If HID card reader: users can only be added/deleted on external reader.

The device Connected with Fingerprint Reader For example:

Connect SF1 as the fingerprint reader to the device.

Step 1: Add the Fingerprint (A) on SF1 (Please refer to SF1 manual)

Step 2: Add the same Fingerprint(A) on the device:

1	Enter Program Mode: -k (Master Code) #
2	1 (Press Fingerprint A once on SF1) # (ID auto allocated) OR 2 1 (User ID)# (Press Fingerprint A on SF1)# (Select specific ID)
3	Exit: *

4.4 The device Connected with Keypad Reader

The keypad reader can be 4 Bits, 8 Bits (ASCII), or 10 Bits output format. Choose the below operation according to the PIN output format of your reader.

Programming Step	Keystroke Combination
1. Enter Program Mode	-k (Master Code) #
2. PIN input bits	8 (4 or 8 or 10) # (factory default is 4 bits)

3. Exit	*
---------	---

Remarks: 4 means 4 bits, 8 means 8 bits, 10 means 10 digits virtual number.

- **Add PIN Users:**

To add PIN users, after enter into programming mode on the device, PIN(s) can be input/ added on either the device or the external Keypad Reader.

- **Delete PIN Users:** the same way as add users.

5 WIEGAND READER MODE

The device can work as Standard Wiegand Reader, connected to the third party Controller ...7 8 #

5.1 Connection Diagram

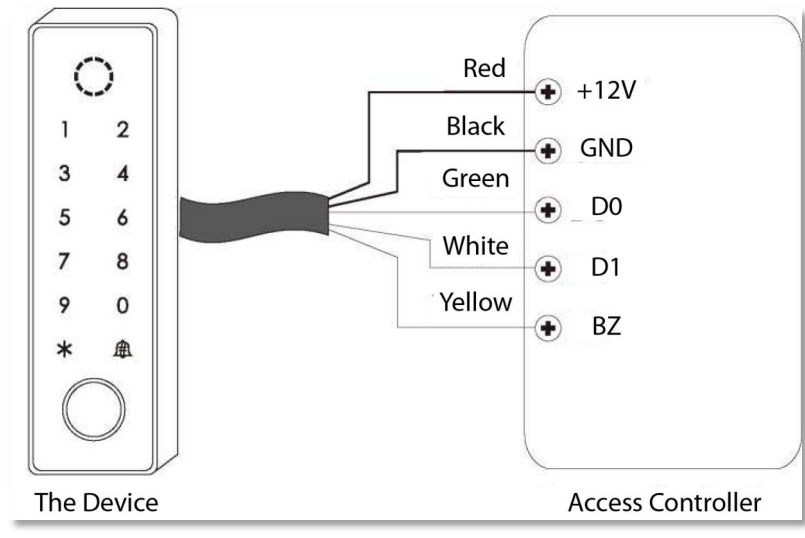

Notes:

- When set into Wiegand Reader mode, nearly all settings in Controller Mode will become invalid, and Yellow wire will be redefined as below:
-Yellow wire: Buzzer control

- If you need to connect Yellow wire: When the input voltage for Buzzer is low, it will sound.

5.2 Set Wiegand Output Formats

Please set the Wiegand output formats of Reader according to the Wiegand input formats of the Controller.

Programming Step	Keystroke Combination
1. Enter Program Mode	* (MasterCode)#
2. Wiegand output bits	For EM Card: 8 (26-44)# (factory default is 26bits) For Mifare Card: 8 0 (26-44, 56, 58) # (factory default is 34bits)
PIN output bits	8 (4 or 8 or 10) # (factory default is 4 bits)
4. Disable Parity Bit	*80#
5. Enable Parity Bit	81# (factory default)
4. Exit	

Note: For connecting Wiegand controller with 32,40,56 bits input, need disable parity bits.

6 ADVANCED APPLICATION

6.1 Collection Card Mode

After this mode is turned on, all cards can open the lock. At the same time, the card is added to the device.

Programming Step	Keystroke Combination
1. Enter Program Mode	* (MasterCode)#

2. Collection Card Mode OFF OR 2. Collection Card Mode ON	9 2# (factorydefault) 93#
3. Exit	*

6.2 User Information Transfer (Valid for Card / PIN Users)

The device supports the User Information Transfer function, and the enrolled user (cards, PINs) can be transferred from one (let's name it Master Unit) to another (let's name it Accept Unit).

Connection Diagram:

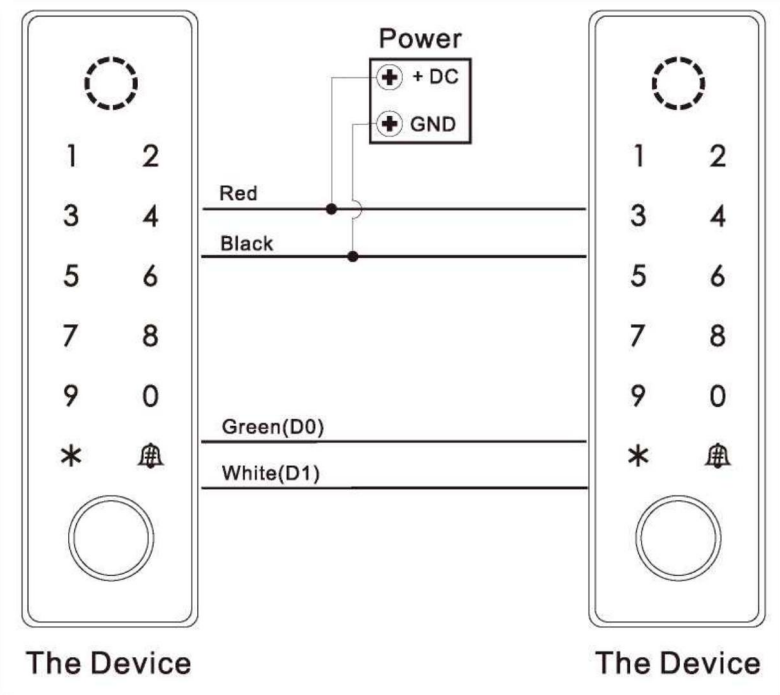

Remarks:

- The Master units and Accept units must be same series devices.
- The Master Code of the Master Unit and the Accept Unit must be set to the same.
- Program the transfer operation on Master Unit only.
- If the Accept Unit is already with the users enrolled, it will be covered after transferring.
- For full users enrolled, the transfer takes about 30 seconds.

6.3 Set Transferring on Master Unit:

Programming Step	Keystroke Combination
1. Enter the programming mode	ie (MasterCode)#
2. Set transferring	98#
Within 30 seconds, Green LED shines, after one beep, the LED will turn into Red, which means the users' information has been transferred successfully.	
3. Exit	*

Simplified Instruction	
Function Description	Operation
Enter the Programming Mode	*- Master Code ■# then you can do the programming (123456 is the factory default master code)
Change the Master Code	0 - New Code - # - Repeat the New Code-# (code: 6 digits)
Add Card User	1 - Read Card - # (can add cards continuously)
Add Fingerprint User	1-Fingerprint- Repeat Fingerprint- Repeat

	Fingerprint Again-#
Add PIN User	1 (User ID)-PIN-# (The PIN is any 4~6 digits)
Delete User	2- Fingerprint-# 2-Read Card-# 2-User ID-#
Exit from the Programming Mode	*
How to release the door	
Fingerprint User	Input Fingerprint
Card User	Read Card
PIN User	Input PIN#

ZKTeco Industrial Park, No. 32, Industrial Road,
Tangxia Town, Dongguan, China.
Phone: +86 769 - 82109991
Fax : +86 755 - 89602394
www.zkteco.com

